

ACCESSIBILITY STANDARDS FOR MULTIFAMILY HOUSING

REPORT ON APPROACHES

WITH FOCUS ON

SLOPE, REACH, TOLERANCE AND MEASUREMENT

THE BLANCK GROUP, LLC

May 26, 2010

Authors

Peter Blanck, Ph.D., J.D.

Michael Morris, J.D.

Richard Duncan, MRP

William N. Myhill, M.Ed., J.D.

ACCESSIBILITY STANDARDS FOR MULTIFAMILY HOUSING

Syracuse, New York, USA

© THE BLANCK GROUP, LLC 2010

blanckgroup@gmail.com

See Appendix 8 for Author Short Bios

Table of Contents

Table of Contents **i**

List of Tables **iii**

List of Figures..... **iv**

Acknowledgments **v**

Executive Summary **vi**

Introduction..... **1**

I. Areas of Study..... **3**

II. Research on Standards Development **6**

 A. Origins of Standards for Accessible Design and Construction 7

 B. Adequacy of the Knowledge Base 11

 C. Relevant Studies 13

 1. Ramp Slope..... 14

 2. Minimum and Maximum Cross Slopes 15

 3. User Perceptions of Cross and Running Slope Differences 16

 4. Effective Reach Range for Wheelchair Users 18

 5. Bathroom Use 19

 D. Implications for Compliance 20

 1. Running Slope and Cross Slope 21

 2. Reach 21

 E. Summary 22

III. Alternative Approaches to Accessibility Standards..... **24**

 A. Alternative Site Slopes 24

 1. Site Tolerances 26

 2. Illustrative Site Slopes 29

 B. Kitchens, Bathrooms, and Environmental Controls 32

 1. Reach and Centering in Kitchens and Bathrooms 38

 2. Environmental Controls and Usability 41

 C. Measurement Protocols 44

ACCESSIBILITY STANDARDS FOR MULTIFAMILY HOUSING

1. Tools and Procedures..... 44

2. Data Collection 45

D. Summary 47

IV. Recommendations..... 49

Appendix 1. Legislative and Standards Development Timeline..... 50

Appendix 2. Fair Housing Safe Harbors 52

Appendix 3. Timeline of Select Studies and Commentary 54

Appendix 4. Regulatory Documents and Definitions..... 56

Appendix 5. Methodology Guide 58

Appendix 6. Settlement Results: Examples 61

Appendix 7. Measurement Tools and Procedures 63

Appendix 8. About the Blanck Group, LLC 65

Endnotes..... 68

List of Tables

Table 1. Federal Laws, Guidelines, and Industry Standards Cited in Court Cases 4

Table 2. Slope Relationships from Kockelman 16

Table 3. Slope Relationships from Vredenburg: Up to a 20-Foot Length of Pathway..... 18

Table 4. Illustrative Slopes for 6-Foot Length of Pathway..... 31

Table 5. Illustrative Slopes for 20-Foot Length of Pathway..... 31

Table 6. Illustrative Slopes for 50-Foot Length of Pathway..... 31

Table 7. Sample Data Points, 4-Foot-Wide Pathway 46

Table 8. Camden: Partial Consent Decree, 6-Foot Length of Pathway 61

Table 9. Kettler and Camden: Settlement Agreement and Consent Decree 62

List of Figures

Figure 1. Grab Bar Locations at Bathtub 20

Figure 2. Alternate Curb Ramp Slopes 29

Figure 3. Obstructed Side Reach 33

Figure 4. Current Side Reach Dimensions..... 34

Figure 5. Less-Restrictive Side Reach Dimensions 34

Figure 6. Old Toilet Centering Standard..... 35

Figure 7. New Toilet Centering Standard 36

Figure 8. D’Souza Unobstructed Side Reach Research Results 38

Figure 9. Parallel Centering at a Kitchen Range..... 39

Figure 10. Centering Shift with Parallel Approach 40

Figure 11. Sample Centering Shift, Lavatory Bowl, Overhead View 41

Figure 12. Less-Restrictive Side Reach Range..... 42

Figure 13. More-Restrictive Side Reach Range 42

Figure 14. D’Souza Unobstructed Side Reach Research Results 43

Figure 15. Sample Data Point Array, 12-Foot Long Pathway, 4 Feet Wide 47

Figure 16. Standard 2-Foot-Long Digital Inclinometer 64

Acknowledgments

This investigation and report would not have been possible without assistance from diverse stakeholders, including designers and builders from the multifamily housing industry and leaders from the disability community; federal, state, and local agency staff; accessibility experts; architects; and developers. We gratefully acknowledge assistance from the National Multi Housing Council. Our goal is to further dialogue, research, and practice to enhance 21st century housing options for all persons, with and without disabilities. The views herein reflect only ours, which may be subject to change or supplemented as this area and information evolves.

Executive Summary

The accessible design and construction provisions for multifamily housing under the Fair Housing Amendments Act (FHAA) of 1988 have led over time to varying interpretations of compliance with the Act. Builders and design professionals rely on such sources as the design requirements found in the Act and detail provided in the *Fair Housing Accessibility Guidelines*, the *Fair Housing Act Design Manual*, and other safe harbors established by the U.S. Department of Housing and Urban Development (HUD). Moreover, developments in science, technology, demographics, and enforcement—as well as a focus on the abilities and inclusion of individuals with disabilities—have created the need for a fresh and independent analysis of the applicability of accessibility standards, codes, and guidelines.

Thus, the National Multi Housing Council commissioned a team of experts with more than fifty years of combined experience in accessible design for single and multifamily housing and related law and policy. The research team investigated the scientific basis for specific accessibility provisions for multifamily housing, and examined select accessible design elements including site features and access, and use of interior space in dwelling units.

Activities informing this report include analysis of (1) accessibility standards such as ANSI (American National Standards Institute) A117.1 and FHAA safe harbors; (2) reports from government and nongovernmental organizations; (3) studies of disability, anthropometric, and ergonomic factors; (4) court documents such as complaints, consent decrees and settlements, and case decisions; (5) scholarly and practice articles; and (6) information from focus groups, interviews, and discussions with leaders from the disability community and multifamily housing industry; architects and accessibility experts; and federal, state, and local agency staff.

In this investigation, we analyze trends in practice and areas of compliance. We review the state of relevant science to understand its validity and applicability to real world situations. We illustrate alternative approaches and procedures that maintain usability and access for persons with disabilities. Our findings support greater usability ranges than select building standards and safe harbors currently allow. We illustrate this point in areas of site slope tolerances and unit interior tolerances for centering and reach.

ACCESSIBILITY STANDARDS FOR MULTIFAMILY HOUSING

Finally, we recommend alternatives for particular accessible design practices as applied to multifamily housing properties. These recommendations include:

1. The consideration of variable cross and running slopes, beyond 2% for cross slopes and 5% for running slopes for specific site circumstances, which are usable for persons with diverse disabilities.
2. The adoption of appropriate tolerances in centering requirements in kitchens and bathrooms.
3. The adoption of appropriate tolerances in upper reach range environmental control locations.
4. The use of measurement devices and protocols for accurate site condition data.

These recommendations support accessible and usable multifamily housing for persons with disabilities. They also illustrate alternative approaches to areas of project design and construction critical to the building industry.

Introduction

The accessible design and construction provisions for multifamily housing under the Fair Housing Amendments Act (FHAA) of 1988 have led over time to varying interpretations of compliance with the Act. Builders and design professionals rely on such sources as the design requirements found in the Act and safe harbors established by the U.S. Department of Housing and Urban Development (HUD) such as the *Fair Housing Accessibility Guidelines*, the *Fair Housing Act Design Manual*, and others. However, the nature of the safe harbors in general, and their use in practice and interpretation, often has confused and even frustrated the intent and ability of some in the design and construction industry to comply with the Act.

During the first decade following passage of the FHAA, relatively few compliance disputes arose; yet this initial period was followed by a substantial rise in complaints.¹ The number of HUD complaints on the basis of disability has risen notably since 2005.² However, violation of FHAA design and construction provisions account for a steadily decreasing proportion of these complaints.³ During this recent period, there have been important changes in science, technology, demographics and enforcement, and a greater focus on the abilities and inclusion of individuals with disabilities. These factors suggest the need for a fresh analysis of accessibility standards, codes, and guidelines.⁴

This report, prepared by a team of experts with more than fifty years of combined experience in accessible design and its attending laws and policies, explores the extent to which research supports existing and alternative accessibility standards in areas of site slopes and specific interior space provisions; application of construction tolerances; and measurement practices for site slopes. The report illustrates alternative means of achieving accessibility for certain features and ensuring compliance while maintaining usability and access for persons with disabilities. It reviews recent research that supports alternatives to specific standards for multifamily housing.

Part I of this report examines FHAA compliance issues and the process by which we decided to target particular areas for our investigations. Part II tracks the development of access standards, reviews the science and research underlying compliance standards (including anthropometrics, ergonomics, user impact studies, and tolerance tests), assesses the accuracy and

ACCESSIBILITY STANDARDS FOR MULTIFAMILY HOUSING

reliability of compliance measurement, and analyzes compliance challenges within current provisions. Part III illustrates an alternative approach to site slope measurement, interior space centering and tolerances, and standardized measurement protocols. Part IV summarizes our recommendations.

I. Areas of Study

The Fair Housing Act was enacted as Title VIII of the Civil Rights Act of 1968.⁵ The enforcement mechanisms, however, were relatively weak, and in 1988 Congress passed the FHAA to strengthen enforcement and extend protection to people with disabilities and others.⁶ Congress gave HUD authority to investigate complaints and initiate suit when it had reasonable cause to believe discrimination occurred. It gave the U.S. Department of Justice (DOJ) authority to bring suit if it had reason to believe there was a “pattern or practice” of discrimination or a denial of rights that raised an issue of public importance. Individual plaintiffs were also provided a private right of action.⁷ In turn, HUD developed accessible “[d]esign and construction requirements”⁸ that reiterated the statutory intent of the FHAA but unfortunately did not offer specific accessibility criteria by which to enforce the FHAA’s mandate.⁹

In 1991, HUD published final rules and the *Fair Housing Accessibility Guidelines (FHA Guidelines)*, which set out a safe harbor option for compliance.¹⁰ A safe harbor in this context is a set of criteria whose fulfillment ensures compliance with the FHAA accessibility mandate (see Appendix 2).¹¹ While the HUD provisions (i.e., standards, guidelines, or requirements regarded as being applicable) apply to housing built since 1991, the number of complaints has increased in magnitude and scope since 2001, particularly from cases brought by DOJ and advocacy groups, and many affecting thousands of housing units. A lack of effective tolerances—that is, reasonable departures from the safe harbors that balance usability, considerations of construction and maintenance—and questions about underlying research and enforcement trends, also has informed the team’s investigation and analysis.

To address these issues, we conducted a review of case law, both in process and resolved; final HUD rulings; consent decrees and orders; settlement agreements in which the DOJ and HUD intervened or were party; other decrees, orders, and agreements generally available through legal and other data bases; and other public sources that maintained records of alleged disability-based housing discrimination in violation of the FHAA or the Americans with Disabilities Act (ADA). We included the ADA as part of this analysis because of its applicability to rental offices and public use areas, and its mandate that public parking areas in multifamily housing developments comply with the slope, width, curb ramp, clearance, signage, location, and parking

ACCESSIBILITY STANDARDS FOR MULTIFAMILY HOUSING

space requirements of the *ADA Accessibility Guidelines for Buildings and Facilities* (ADAAG).¹²

Through this review, we collected 134 relevant cases between 1991 and 2008. To assess accessibility issues and their frequency in the cases identified, we analyzed each case in terms of the parties involved and the types and numbers of alleged and concluded violations.¹³ We found the issues raised may be thematically organized into twelve general areas. These were: (1) path slope in common areas, (2) path slope in public areas, (3) bathroom and kitchen maneuverability in units, (4) bathroom wall reinforcement in units, (5) placement of light / environmental controls in units, (6) placement of outlets in units, (7) door width in units, (8) door threshold in units, (9) door hardware in units, (10) door hardware in common areas, (11) designated parking signage in public areas, and (12) curb cuts in public areas.

Next we identified the statutory or regulatory provisions, standards, or guidelines that the courts and parties cited regarding compliance with the FHAA or ADA issue raised (see Table 1). The documents reviewed did not address any specific factual issues, such as measurements of the alleged violations.

Table 1. Federal Laws, Guidelines, and Industry Standards Cited in Court Cases

1. Fair Housing Amendments Act (generally).
2. Americans with Disabilities Act (generally).
3. 42 U.S.C. §3604(f) – FHAA provision regarding discrimination in the sale or rental of housing and other prohibited practices.
4. 24 C.F.R. §100.205 – FHAA provision, regarding design and construction requirements.
5. 56 Fed. Reg. 9472 – Final Fair Housing Accessibility Guidelines (Mar. 6, 1991).
6. *FHA Guidelines*, 56 Fed. Reg. 9472, 9499–9512.
7. ANSI A117.1 (specific versions commonly not indicated).
8. 54 Fed. Reg. 3243 – “Section 100.135 Unlawful practices in the selling, brokering, or appraising of residential real property.”
9. 28 C.F.R. Pt. 36, App. A - ADA Standards for Accessible Design (codified version of the ADAAG).
10. *FHA Design Manual*.

ACCESSIBILITY STANDARDS FOR MULTIFAMILY HOUSING

Our findings show the ANSI standards, in conjunction with the FHAA statute and regulations and the *FHA Guidelines*, were relied on most often by the courts and parties to these cases. Notably, two safe harbors, the *2000 ICC Code Requirements for Housing Accessibility* and the *International Building Code*, were not used. The content analysis of legal cases was considered in light of our interviews with housing industry and disability community members to illuminate the areas examined in this report. Thus, our review of the standards (including ANSI A117.1) and their application to multifamily projects includes consideration of practice, anecdotal information, expert opinion, and personal experience. Further, we have considered findings from relevant research that was relied on in the standards development process. As discussed in Part II, analysis of this research suggests that accessibility standards, guidelines, and codes have not consistently reflected the present state of ergonomic and anthropometric science.

In summary, the legal analysis outlined above, combined with the results from interviews, and the review of research (covered in Parts II and III) suggest that among frequently disputed accessibility issues, several stand out with questionable research and enforcement underpinnings. These are path site slope; bathroom and kitchen centering and reach; and environmental control locations, such as for light switches and thermostats. Because site measurement methodology and protocol contribute to accurate site data gathering, they also were selected for review.

II. Research on Standards Development

Multifamily housing accessibility standards and safe harbors contain scores of quantitative and dimensional provisions addressing such areas as bathroom and kitchen space, environmental controls, and pathway site slope. Accessibility guidance is intended to provide the multifamily housing industry with parameters for design and construction that result in facilities usable by a diverse population, including persons with disabilities. However, as the studies we review illustrate, there often may be a difference between accessible environments (i.e., those compliant with a standard or guideline) and usable environments, particularly for persons with varying types and severity of disabilities. Varying locations, widths, heights, and site slopes result in different levels of usability for diverse users. Building features and dimensions that meet accessibility provisions do not necessarily result in appropriate usability for people with different disabilities.

Passage door width provides a simple example of such a spectrum of usability: A 5-foot-wide doorway may offer no impediment to users of varying sizes with different types of mobility equipment. By contrast, a 2-foot-wide doorway is usable by a few, inconveniences most others, and prevents passage for almost anyone using wheeled mobility equipment. Thus, there is a distribution of usability, with narrower doorways allowing passage to fewer people with disabilities who use wheelchairs. Of course, judgments of usability based on large doorway differences are straightforward. Evaluations of smaller yet often significant differences in door width (such as one-inch or less) that affect fewer users are more complex. The analysis of this type of distinction in accessible building design and construction is the focus of this report.

As we propose, this same distributional idea of usability applies to particular accessibility features examined in this report: pathway site slopes, environmental control locations, and unit interior centering and tolerances. Acknowledgement of the usability distribution not only helps frame the appropriateness of certain dimensional accessibility tolerances but also highlights the limitations of rigid or vague construction tolerances. Part II of this report examines the research basis for specific accessibility standards, considering accessibility, usability, and related compliance issues.¹⁴

A. Origins of Standards for Accessible Design and Construction

Conceptions of usability and accessibility in design and construction provisions predated the 1988 FHAA (see Legislative and Standards Development Timeline, Appendix 1). Pioneering research by Timothy Nugent at the University of Illinois at Urbana-Champaign between 1949 and 1960 laid the groundwork for the 1961 standard of the American Standard Association (ASA), 117.1: *Specifications for Making Buildings and Facilities Accessible to, and Usable by, the Physically Handicapped*.¹⁵ In 1949, as a veteran of World War II, Nugent founded the Disability Resource and Educational Services (DRES) program with fellow veterans who acquired physical disabilities.¹⁶ These programs were considered to be among the most innovative programs and services in the country.¹⁷

ASA Project A-117, as it was known, began in 1959 at the request of the President's Committee on the Employment of the Physically Handicapped.¹⁸ Nugent and others met with the ASA (hereinafter American National Standards Institute, or ANSI),¹⁹ formed a steering committee, and established the ANSI Sectional Committee on Facilities in Public Buildings for Persons with Physical Handicaps.²⁰ Over the next two years, the committee—representing more than fifty professional disciplines and trades, associations and government agencies—gathered and reviewed research, standards, and subject matter applicable to accessible design.²¹ The committee then implemented a comprehensive work plan requiring individual members to independently investigate specific project areas.²² Nugent began a series of experiments addressing ramps, site slopes, surfaces, turning space, and reach, as well as the use of commercial products to solve accessibility challenges (See Appendix 3. Timeline of Select Studies and Commentary).

Nugent involved seventy-three participants with physical impairments who required the use of a wheelchair.²³ He evaluated participants using neurological, anthropometrical, and muscular tests. Group members varied in manifestation and etiology of disability, age, age of disability onset, and duration of time functioning with a disability. The participants engaged in thousands of iterations of these experiments. Each person wheeled up and down ramps in thirty-two orientations (varying in length, pitch, or combinations of both) multiple times. Each crossing was timed to the tenth of a second, observed, and after each crossing rated by participants for degree of difficulty on a five-point Likert scale.²⁴

ACCESSIBILITY STANDARDS FOR MULTIFAMILY HOUSING

Nugent and other researchers helped create the field of human factors. Human factors, often called ergonomics, address “physical output activities” (e.g., studying the musculoskeletal system, energy expenditure, physiological stress, and anthropometry) as well as the “arrangement and utilization of physical space” and the environment.²⁵ Several areas of human factors research are relevant to our purposes here: anthropometry (“measurement of the physical features of the body” at rest and in motion for the design of products and spaces);²⁶ biomechanics (body movement involving strength, range of motion, accuracy, speed, and endurance, especially useful in determining locations for environmental controls and information displays);²⁷ and task-environment research, addressing unique environments such as bathrooms and kitchens.²⁸ Anthropometry has formed the basis for accessibility and fire safety codes, standards, and guidelines in architectural and interior design.²⁹

By 1960, before the official publication of the new accessibility standard, questions were raised about construction evaluation methods and procedures, design impact on human requirements and behavior, and needed engineering and social science research to inform the field.³⁰ The pending standards were based on early and limited research on architectural needs of people with disabilities, primarily for persons with mobility and upper body impairments.³¹ In 1961, ANSI approved the committee’s A117 standards (hereinafter ANSI A117.1)³² and began its dissemination to legislatures, professional organizations, and other groups for possible adoption.³³ Between 1961 and 1967, forty-four states implemented accessibility standards for public facilities.³⁴ Ninety-five cities with populations of more than 50,000 and forty-two metropolitan counties similarly responded.³⁵ During that time, the ANSI A117.1 standards were adopted outright in fourteen states, in part by fifteen states, and were pending adoption in additional states.³⁶

Congress enacted the Vocational Rehabilitation Act of 1966, which established the National Commission on Architectural Barriers to Rehabilitation of the Handicapped, to address barrier inaccessibility at the federal level.³⁷ The Commission secretary appointed fifteen members from public, private, and professional groups to develop solutions to architectural inaccessibility problems.³⁸ Despite the ANSI A117.1 standard’s seemingly widespread adoption, the Commission worked with the American Institute of Architects (AIA), ANSI, and professional associations to explore why the 1961 standards were not more widely used and implemented.³⁹

ACCESSIBILITY STANDARDS FOR MULTIFAMILY HOUSING

In 1968, the Commission produced a report, *Design for All Americans*, which noted resistance by uninformed architects, building supply manufacturers, state and local building code officials, and the general public to implementing the 1961 standards.⁴⁰ The report concluded that the standards were vague or silent on residential housing requirements, the identification of covered facilities, and the extent of compliance necessary.⁴¹ It found a lack of research and data to assess the impact of inaccessibility in terms of persons affected, avoidable insurance costs, tax dollars expended on unemployed persons with disabilities who are unable to physically enter the workplace, and accessibility retrofitting.⁴² The report called for federal legislation requiring the design of new public buildings and facilities to accommodate the elderly and persons with disabilities when federal funds were used in their construction.⁴³

To implement the Commission's recommendations, Congress passed the Architectural Barriers Act (ABA) in 1968,⁴⁴ adopting ANSI A117.1 as the technical standard.⁴⁵ Thereafter, Congress passed the Rehabilitation Act of 1973, which created the Architectural and Transportation Barriers Compliance Board (later changing its name to the U.S. Access Board or simply Access Board).⁴⁶ The Access Board is a federal agency focused on accessibility for people with disabilities. It develops and maintains design criteria for the built environment, transit vehicles, telecommunications equipment, and electronic and information technology.⁴⁷

By the early 1970s, a new generation of researchers and disability advocates began discussing the need for comprehensive ANSI standards in public and private construction, which would add specificity and descriptive illustrations, and address residential facilities.⁴⁸ Professor Edward Steinfeld at the University of Buffalo noted the limitations of the available research to inform accessible design.⁴⁹ A team headed by Steinfeld and in collaboration with Syracuse University, undertook a HUD-funded project to review human factors and data to inform revisions to ANSI A117.1.⁵⁰ Steinfeld reported, "Unlike other areas ... human factors research has consistently produced hard data directly applicable to design and with the goal of [creating] a better fit between people and their physical surroundings."⁵¹

Yet, existing anthropometric data largely were based on military populations, thus under-representing women, children, persons with disabilities, and people over age 50.⁵² The few anthropometric studies including people with disabilities focused primarily on people using wheelchairs and addressed such issues as turning radius and reach height.⁵³ Limited

biomechanical data about people with disabilities were available for endurance, such as on ramp slopes, and a paucity of information about range-of-motion for people in general.⁵⁴

A few studies on task and environment included tests of people maneuvering wheelchairs in tight spaces. However, as a general matter, studies of kitchens and bathrooms excluded people with disabilities.⁵⁵ Prior research also relied on data from laboratory settings, used small sample sizes, and did not consider individual characteristics such as disability severity.⁵⁶ There was a growing desire for standards that went beyond existing provisions and which would be informed by human factors and empirical research involving populations with diverse disabilities.⁵⁷

In 1979, Steinfeld and colleagues began a series of studies involving fifty-four participants to address counter heights and reach limits; maneuverability; and size and placement of bathroom stalls and tubs, elevators, ramps, kitchens, and public telephones.⁵⁸ This line of study was the first on accessible design with participants with disabilities. However, Steinfeld's research did not address or resolve all pending issues. For instance, measurements of space requirements for a wheelchair making a 180-degree turn, as found by the 1979 Steinfeld study and compared to three prior studies, varied by as much as 34%.⁵⁹ Of these four studies, only the Steinfeld and Walter (1971)⁶⁰ on people's use of circulation space around doorways, ramps and in vehicles withstood the scrutiny of publication.⁶¹

Ramp slope research showed similar variability. A review of findings from the 1979 Steinfeld study and two prior studies (Elmer, 1957; Walter, 1971) show a 100% variance in their findings.⁶² It is difficult therefore to draw meaningful generalizations from such disparate research results. In 1980, informed by Steinfeld's research, ANSI A117.1 nonetheless was revised and expanded in detail and scope. Importantly, the 1980 revision added accessibility information for restrooms and ventured into topics such as curb ramps, dwelling units, and assembly areas.⁶³

Thereafter, research efforts increased, albeit with continuing limitations in methods, sample sizes, and measurement of individual differences, making "it impossible to combine findings to create a database that allows a higher level of generalizability."⁶⁴ The ANSI A117.1 standards were revised again in 1986 during discussion about development of a national housing accessibility standard.⁶⁵ The 1986 changes were targeted toward individuals with sensory disabilities, addressing alarm and communication systems, and meant to align ANSI with the

Uniform Federal Accessibility Standards (UFAS, adopted in 1984 and drafted to implement the ABA).⁶⁶ This state of the science would improve slowly in the coming decades.

B. Adequacy of the Knowledge Base

Following introduction of the 1986 ANSI A117.1 standards, research continued to increase the multifamily housing accessibility knowledge base in discrete ways. That base, however, has remained largely incomplete for effectively informing practice and future standards development. In this section, we review the specific shortcomings of the knowledge base and how the research community has proposed and begun to close that gap.

In 1986, Dr. Clifford Brubaker and colleagues at the University of Virginia Rehabilitation Engineering Center published a study on the impact of the downhill turning tendency of manual wheelchairs when encountering side and cross slopes, primarily those designed for water drainage and runoff.⁶⁷ The research team aimed to quantify downhill turning factors and recommend ways to better control wheelchairs.⁶⁸ One participant, a male, age 20, with paraplegia, using one standard and one sport wheelchair, took part in the study to measure drag forces, heart rate, oxygen consumption, and stroke rate.⁶⁹ The participant drove each wheelchair on a large treadmill moving at three or four kilometers per hour. The treadmill was positioned at a 0-degree slope and a 2-degree slope (created by raising one side of the treadmill parallel to the side of the wheelchair).⁷⁰ Drag was about twice as large on the 2-degree slope as it was on level surfaces. On the sloped surface, oxygen consumption increased by 30%, and the force needed to move the wheelchairs increased more than 100%.⁷¹

The Brubaker study provided preliminary insight into and data addressing important biomechanical factors for persons using wheelchairs on slopes. However, its use of one participant limited implications for accessibility standards and wheelchair design, and generally exemplified the limitations of studies during this period.

Thereafter, studies and analysis by leading researchers confirmed three major challenges to the accessibility research knowledge base, namely (1) adequacy of the sampling numbers, diversity, and representativeness, (2) accuracy of measurements and data collection, and (3) inclusion of the changing mobility technologies. Steinfeld, for instance, observed that due to unrepresentative sampling distributions, insufficient data across ages and types and severity of disabilities, and changes in performance characteristics resulting from new wheelchair

technologies, most data sources were not adequate for meaningful analysis.⁷² Bradtmiller (Anthrotech, Inc. Yellow Springs, OH) similarly identified limitations caused by small samples, poor measurement techniques, unfocused hypotheses, invalid restrictions on assessed dimensions, and lack of diversity of disability type and severity.⁷³

Specifically, research participants often have been self-selecting or drawn from clinics and institutions, and thus not representative of the range of people with disabilities.⁷⁴ Sampling techniques have reflected neither individual variation as a function of disability type and severity, nor changes in functionality over time.⁷⁵ Researchers widely agree that samples have not been adequate “to understand the variation across individuals and groups or to insure that findings are representative of the entire population.”⁷⁶ Anthropometric and ergonomic data remain limited in their applicability and reliability.⁷⁷ Accordingly, designers and policymakers developing and implementing accessibility provisions continue to be “hampered by a lack of appropriate anthropometric data (for people with disabilities),” on which to base accurate design requirements.⁷⁸

Leading researchers have proposed and begun implementing a variety of studies to remedy the inadequacy of the knowledge base. In the 1997 research commentary *Anthropometry for Persons with Disabilities: Needs for the Twenty-First Century*, Bradtmiller and colleagues called for a national effort to gather comprehensive anthropometric data.⁷⁹ The report articulated the need for body size descriptors, reach capabilities, “range of joint motion,” “arm and hand strength measurements,” “visual field data,” and “wheelchair/user measurements.”⁸⁰ Researchers further noted the need to understand the relationships of these capacities to age, disability, stature, and other factors,⁸¹ and to gather data from children and adults across the spectrum of disability.⁸² Steinfeld further advocated for the inclusion of elderly populations in light of shifting demographics and the aging workforce.⁸³

In 2003, the Access Board funded a workshop to develop standardized anthropometric research procedures, and to foster new and valid approaches for researchers, policymakers, practitioners, and designers.⁸⁴ In the resulting report, *Space Requirements for Wheeled Mobility: An International Workshop*, Steinfeld and Dr. Victor Paquet (University of Buffalo) emphasized the need for acknowledgment of technological innovations in research (e.g., “high degree of variability in the turning radius and stability of powered wheelchairs” and demands for larger

wheeled-mobility devices); and the nature of the changing disability consumer base (e.g., greater demand for wheeled mobility use, more older women and younger men using these devices, and health complications among wheeled mobility users).⁸⁵ Open source modeling tools now permit multiple researchers to gather and use data from standard measurement protocols.⁸⁶ Additionally, Steinfeld has recommended use of participants in longitudinal studies to understand disability and the aging process.⁸⁷

In *Space Requirements for Wheeled Mobility*, Steinfeld and Paquet emphasized the possibilities for 3D digital human modeling technologies to enhance anthropometric data sets (discussed in Part II, section C, below).⁸⁸ Builders and designers are said to benefit from 3D techniques that provide “design-specific information” on the person and environment interaction.⁸⁹ Computational and automated data collection techniques may replace many manual anthropometric measurements,⁹⁰ and support specialized measurement techniques to generate anthropometric data for people with disabilities.⁹¹ These recent research and computational approaches, however, do require future validation.⁹² Finally, reflecting on the decades of past research, Steinfeld has stated that sufficient data are finally beginning to emerge to effectively inform revision to accessibility standards.⁹³

C. Relevant Studies

The recent and illustrative studies discussed in this section reveal areas of limitation with current accessibility standards. They also address the validity and usability of dimensional provisions and raise new issues. A particular focus of this report is the accessibility provisions for site slope and interior unit spaces of multifamily housing. Multifamily housing design and construction is guided by the *Fair Housing Act Design Manual*, ANSI A117.1, and other HUD-established safe harbors. Nevertheless, we review and analyze studies that also address provisions under the ADA because the ADAAG dimensional provisions are substantially similar to and reference HUD safe harbors. In addition, we draw on comparable figures from the *ADA Accessibility Standards* because of the quality of the available images.

Certain dimensional provisions have survived for decades in accessibility standards. In this report we do not make the case for replacement of those provisions. However, our analysis raises questions about some of these provisions from a usability and practical point of view,

particularly as applied to diverse users with disabilities in both outdoor and indoor environments, and to design, construction, and facilities management and maintenance.

1. Ramp Slope

Jon Sanford and colleagues at North Carolina State University evaluated the range of ramp slope usability for diverse persons with disabilities using various mobility devices.⁹⁴ They assessed the ramp slope requirements of the ADAAG, which allows for a 1:12 maximum slope over 30 feet to a 1:8 maximum slope for a 6-inch rise.⁹⁵

The range of allowed ramp slopes expressed in all guidelines and standards is from the steeper slope of 1:12 to a gentler slope of 1:20. Current provisions allow for exceptions with steeper ramp slopes of 1:10 and 1:8, but only for short distances. An inclined surface with a slope greater than 1:20 (e.g., with less steep slopes of 1:22 or 1:25) escapes certain ramp provisions such as the requirement for handrails or a level landing for every 30 inches of rise.

Sanford's participants were asked to travel across a 30-foot aluminum ramp adjusted to seven slopes: 1:20, 1:16, 1:14, 1:12, 1:10, and 1:8.⁹⁶ The sample included 171 participants across eight general disability categories and six age groupings, using varying mobility aids (e.g., canes, braces, walkers, and manual wheelchairs).⁹⁷ Participants rated ramp difficulty and the degree to which the testing conditions represented real-life situations.⁹⁸ The researchers assessed participant "pulse rate, energy expenditure, rate of travel, distance traveled, and the location of rest stops."⁹⁹ The study used self-selecting participants, limited to those in good health, and the ramp was not subjected to weathering conditions.¹⁰⁰

The analysis of a 1:12 running slope found 85% of participants could travel thirty feet using manual wheelchairs, and almost all participants using other mobility aids (e.g., canes, braces and walkers) could traverse thirty feet.¹⁰¹ Additionally, 80% of participants could travel thirty feet using manual wheelchairs at a running slope of 1:10, and 75% at 1:8.¹⁰² No significant energy expenditures were found for this length at 1:8 slopes.¹⁰³ Only participants using manual wheelchairs experienced significant speed decreases due to slope and increases in pulse rate.¹⁰⁴ Persons using walkers perceived greater difficulty ascending and descending steeper slopes than those using other mobility aids.¹⁰⁵

Almost all participants using manual wheelchairs (95%) could ascend 30-foot maximum slopes of 1:14, and 85% of participants still could at 1:12.¹⁰⁶ Participants using wheelchairs and braces experienced greater changes in pulse rate at each increased gradient than did those using canes and walkers.¹⁰⁷ Similarly, only those using manual wheelchairs and walkers rated the difficulty of slopes above 5 on a 10-point scale.¹⁰⁸

Factors of age, gender and type of mobility aid were related to participant ability to ascend ramps and effort expended.¹⁰⁹ Sanford's findings support the obvious relationship between increasing slopes and difficulty in navigation. While the study showed some participants had problems at certain slopes and distances, the results were not sufficient for him to recommend decreasing the 1:12 maximum allowed slope for 30-foot ramps, for instance, to a less steep slope of 1:14.¹¹⁰ The study demonstrates that optimal performance for every person is not always achievable with accessibility standards. To date, ramp slope accessibility standards have remained unchanged.

2. Minimum and Maximum Cross Slopes

Dr. Kara Kockelman and colleagues (University of Texas at Austin) conducted two studies on desirable minimum and maximum cross slopes at driveway crossings on pathways and across extended walking areas, considering the physical exertion required and user perception of difficulty.¹¹¹ The first study involved nineteen participants with varying causes of mobility impairments (e.g., from cerebral palsy, head injury, polio, single leg amputation, paraplegia, or blindness) in two natural environments.¹¹² The researchers collected participant data on cross and running site slope, path width and length, and heart rate.¹¹³ The second study used data from an additional fifty participants as well as data from seventeen of the subjects from the first study. The participants negotiated both directions of a five-section path "configured in a parking lot with both primary and cross slopes."¹¹⁴ Participants traveled the sections in succession to allow heart rate stabilization.¹¹⁵

Kockelman recommended relaxed slope requirements for some circumstances. She found path distance, increased cross and running slopes, and participant age and physical fitness, related to heart rate.¹¹⁶ However, the second study did not find a cross slope effect on heart rate.¹¹⁷ Critical cross slopes (i.e., with "unacceptable levels of effort and/or discomfort") were found to be from 5.1% to 7.4% or more, with a running slope of 5%.¹¹⁸ Critical cross slopes rose

to 6.5% and 8.8% at a 0% running slope.¹¹⁹ Users of canes and crutches, followed by users of manual wheelchairs, perceived the greatest difficulty with cross slope.¹²⁰ Kockelman concluded the 2% ADA cross slope maximum was “less than one half of the values estimated to be critical.”¹²¹ Despite these findings, the researchers limited their recommendations, noting, “cross slopes of 6 percent or more ... should probably” be permitted “when the main slope is minimal.”¹²² Thus, running slopes at 5% may be paired with cross slopes of as much as 5%. While the recommendations reflect the relationship between cross and running slopes, no mention is made of distance traveled.

Extrapolating from the recommendations in Kockelman’s second study (where no slope table was provided), Table 2 represents the relationship between running and cross slopes. In developing this table, we interpret terms used by Kockelman, such as “should probably...permit” and “minimal.”¹²³ The table illustrates possible maximum cross and running slopes of 7%, under constraints of one factor on the other. The shaded areas represent our extrapolation of Kockelman’s recommendations for acceptable standards.

Table 2. Slope Relationships from Kockelman

Running Slope	0%	1%	2%	3%	4%	5%	6%	7%
Cross Slope								
2.0 %								
2.5 %								
3.0 %								
3.5 %								
4.0 %								
4.5 %								
5.0 %								
5.5 %								
6.0 %								
6.5 %								
7.0 %								

3. User Perceptions of Cross and Running Slope Differences

Dr. Alison Vredenburgh and colleagues (Vredenburgh & Associates, Carlsbad, CA) investigated the way persons using motorized and manual wheelchairs perceive cross or running

slope differences.¹²⁴ Their research tests the perceived impact of small site slope variations at low grades on participant effort and perceived inconvenience.

The researchers recruited seventy-nine male and female participants between the ages of 13 and 77, with various mobility disabilities including paraplegia and quadriplegia, arthritis and diabetes, and balance disorders; they also included participants without disabilities. They noted the length of time the individual had had the disability and full- and part-time use of mobility assistive devices (e.g., cane, walker, scooter, manual wheelchair).¹²⁵ The study involved two 20-foot aluminum ramps positioned in an L-shape.¹²⁶ Participants using manual wheelchairs tested and rated cross slopes (forty-three participants) and running slopes (twenty-seven participants) using the Borg Ratings of Perceived Exertion (RPE) scale. The RPE scale involves a subjective analysis whereby participants rate exertion during a particular activity.¹²⁷

Participants were asked to detect cross slopes between 2% and 6%. They rated these slopes “as requiring light or very light effort to travel the length of the ramp.”¹²⁸ Participants often did not reliably identify cross slope differences on ramps with running slopes of 2% to 5%. In addition, the study reported participants had difficulty identifying running slope differences of 5% and 7%.¹²⁹ The participants’ uncertainty in this regard led Vredenburg, in part, to conclude that running slopes up to 8% posed little difficulty to most participants, and running slopes generally posed greater perceived difficulties than cross slopes.¹³⁰

Vredenburg suggested that within the limitation of a twenty-foot pathway length, cross slopes of 5% were possible with running slopes of 2% or less, and “a maximum running slope of 7% was possible when the cross slope is 2% or less.”¹³¹ The shaded areas in Table 3 display the slope relationships from Vredenburg’s study across the range specified. The Vredenburg study does not address the non-shaded areas of Table 3.

Table 3. Slope Relationships from Vredenburg: Up to a 20-Foot Length of Pathway

Running Slope	0%	1%	2%	3%	4%	5%	6%	7%
Cross Slope								
1.0 %								
1.5 %								
2.0 %								
2.5 %								
3.0 %								
3.5 %								
4.0 %								
4.5 %								
5.0 %								

4. Effective Reach Range for Wheelchair Users

Clive D’Souza (University of Buffalo) measured the effective reach range of participants using wheelchairs by breaking down their near environment into regions and recorded the percentage of subjects who could reach into each region.¹³² Thus, data reporting was limited to region size, which measured approximately 3.9 by 3.9 inches (100 by 100 millimeters). Variations of reachability within these regions were not detailed. The study included 257 participants who used one of three mobility devices (scooters, and manual or powered wheelchairs). Participants had diverse chronic conditions, averaged 49 years old, and averaged 21.6 years since disability onset.¹³³ Three-dimensional digital landmarks were collected using an electromechanical probe for each mobility device and participant to establish reference points for measurement and comparison.¹³⁴

Participants placed a lightweight cylindrical object on a shelf at the maximum distance they could manage above and below in three directions (i.e., forward, sideways, and a 45 degree intermediate direction). D’Souza then constructed “reach envelopes,” which were “superimposed on the 3D digital model of the individual-mobility device system using a common origin point.”¹³⁵ Thereafter, the researchers calculated “distances between any pair of three-dimensional body or mobility device landmarks and reach coordinates,” and reach ranges.¹³⁶

Findings were presented for participants who could make a “functional grasp” above the shoulder with an extended forward or lateral reach.¹³⁷ Relevant to this report, almost all

participants (97%) could reach the same height using a lateral reach.¹³⁸ This finding will be examined in more detail below in regard to placement of environmental controls.¹³⁹

5. *Bathroom Use*

In a study on bathroom accessibility, Sanford identified an instance when accessibility standards diminish usability by older people. He collected data from 777 participants age 55 and older to assess ease of use of tubs and showers. The tub/shower combination, even with transfer seat and grab bars, “was the most difficult fixture to use,” and participants “reported less difficulty using a bathtub with a seat than a roll-in shower without a seat.”¹⁴⁰ For example, Sanford suggests older persons requiring bathing assistance “due to difficulty standing for extended periods of time” may benefit little from ADAAG-compliant grab bars.¹⁴¹

The ADAAG and the *ADA Accessibility Standards* require fixed-in-place, horizontally mounted bars on the side and rear walls of tub/shower units as shown in Figure 1.¹⁴² These multiple bar locations do not accommodate the differing heights, strengths, reach ranges, and bending abilities of many users, especially older individuals.

Figure 1. Grab Bar Locations at Bathtub

(ADA Standards for Accessible Design, 1994)

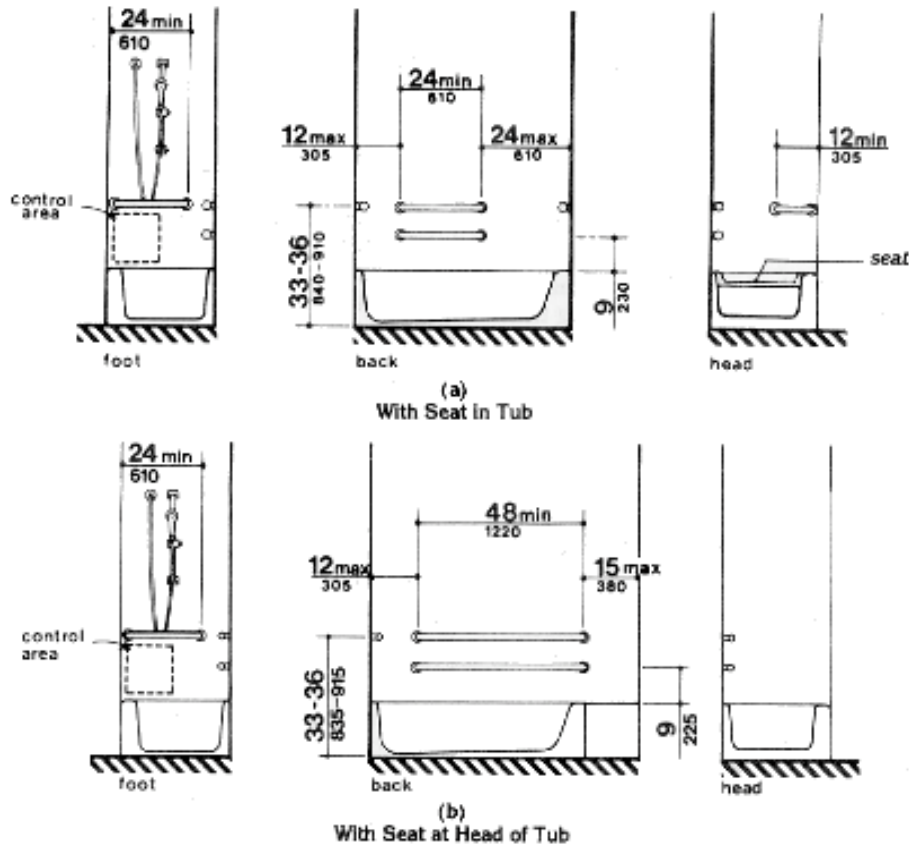

Because of reliance on accessibility guidance documents, Sanford suggested, “code requirements may be restricting our ability to deliver environments that [facilitate] independence and safety for the older population.”¹⁴³ This study illustrates that accessibility standards sometimes require additional research to meet the usability needs of their intended beneficiaries.

D. Implications for Compliance

We have observed that pathway site slopes and reach ranges, among other building features, historically have not benefited from application of reliable study data.¹⁴⁴ Recent research sheds light on these two areas, leading to the conclusion that new approaches should be considered in accessibility provisions for pathways and space provisions in kitchens and bathrooms.

1. *Running Slope and Cross Slope*

The studies we have reviewed suggest that certain differences in running and cross slopes may not substantially affect usability for persons using wheelchairs. Thus, tolerances from pathway slope standards may be appropriate. Vredenburgh's research suggests manual wheelchair users may comfortably travel on pathways with slopes other than the 2% cross slope and 5% running slope maximums currently required.¹⁴⁵

Kockelman's preliminary conclusions suggest a 2% maximum cross slope is unnecessarily restrictive over short distances, such as driveway entrances across sidewalks or "where terrain and/or other conditions do not permit such gradual slopes."¹⁴⁶ These results do not resolve the degree to which subtle differences are detectable in a cross or running slope with variations above the current maximum slopes.¹⁴⁷ Kockelman, Vredenburgh, Sanford, and others acknowledge that energy expenditure, force, mechanical steering, and perceptual issues should be considered when balancing compliance and usability. Their work supports the need for increased running and cross slope tolerances, particularly in environments where cross slopes change over time.

2. *Reach*

Existing accessibility requirements, standards, and guidance documents and recent research produce a mixed picture of the development of reach range provisions. Yet relevant accessibility standards have been modified in recent years to provide greater ease of use. For example, the 1994 *ADA Standards for Accessible Design* allow a high side-reach of no more than 54 inches.¹⁴⁸ Since then, the high side reach range has been reduced to 48 inches, as first appearing in ICC/ANSI A117.1 1998, and then the 2003 ANSI A117.1 standards and the revised 2004 *ADA/ABA Guidelines*.¹⁴⁹

Our interviews suggest that an element of the ANSI committee's initial review of this issue included research from *Obstructed Reach Range Survey of Adult Dwarfs* (August 1996) and *Anthropometric National Survey of Adult Dwarfs* (July 1995).¹⁵⁰ Transcripts of ANSI committee meetings and Task Groups document the difficulty that many little persons had in reaching high. No parallel discussion was found identifying problems that individuals of average height had, for instance, in reaching to 48 inches when compared to 54 inches high. Presumably, it was viewed that those of average stature had no trouble with the downward shift in the new

reach limit. This situation illustrates the challenges in standards development to accommodate diverse users; in this case, involving relatively few individuals who face a significant barrier from the provision of a 54-inch high side reach limit.

However, recent research, such as by D'Souza, suggests many persons in other impacted groups may reach to and beyond this new lower reach limit. Thus, the results of the 2009 D'Souza study suggest a predictable "reachability" range: all participants (100%) could reach a region close to their front reach. By contrast, slightly more than one-third (37%) of the participants could reach to the region farthest away.¹⁵¹ However, adjacent regions often show differences that are marginal. For example, some adjacent regions that straddle the ADA's lateral high reach limits (48 inches) have differences as slight as 2% to 4%.¹⁵² It is difficult therefore to establish a wide difference in usability (here, "reachability") between adjacent regions with such small differences in results.

E. Summary

This Part has reviewed early research that contributed to development of accessibility standards. While significant, this research demonstrates the need for additional and rigorous study, an examination that has begun to emerge only recently. We also reviewed limitations in research that hamper development of valid and reliable accessibility standards. We have found past studies, for instance, provide little guidance for determining valid site slope provisions. Our review underscores the foundational limits for certain accessibility provisions. Prominent researchers agree that past evidence is sparse, and lacks validity or reliability for certain accessibility provisions and for how people across the spectrum of disability interact with their environment. Existing anthropometric and ergonomic data also are limited, using small, unrepresentative samples that omit participants with disabilities; many studies lack individual relevance, using artificial settings not relevant to testing real-world accessibility issues. Advances in science and technology have made data collected in the 1950s to 1970s outdated.

Additional studies examined human and environmental interactions in certain accessibility provisions. These raise questions about the soundness of select accessibility standards. In particular, Sanford's tub usability study questioned the usefulness of accessibility requirements within bathrooms. D'Souza made no recommendation, though his findings raise questions about reach range requirements. In particular, the D'Souza study suggests functional

ACCESSIBILITY STANDARDS FOR MULTIFAMILY HOUSING

reach ranges that extend beyond current upper reach range limits. Kockelman and Vredenburgh made recommendations that challenge accessible site slope standards. In summary, they support expanded tolerances consistent with individual user needs. Overall, researchers generally agree on the importance of using a broad and representative group in person-environment studies. Studies need to consider a range of individual performance characteristics, including height, weight, visual acuity, mobility, and balance, to understand how different people interact with particular environments. However, even when certain accessibility standards address specific individual needs, these same standards may result in a lack of usability for others.

III. Alternative Approaches to Accessibility Standards

This Part examines alternative approaches to site slopes and site measurement, reach and centering provisions in kitchens and bathrooms, and environmental control locations. We review the relevant research, examine the standards development process, and assess the current status and handling of tolerances. We present an illustrative template for alternative site slope and interiors parameters to account for variations while ensuring usability. Finally, we propose a measurement protocol for site data collection to ensure accurate assessment of site conditions.

A. Alternative Site Slopes

This section reviews the limited research on which to base site slope provisions in accessibility standards. It then discusses opportunities for improving these provisions with guidance from recent research findings. Finally, we present illustrative alternative site slopes for usability and compliance.

We have reviewed scientific evidence that shows a range of usability for slopes and cross slopes beyond 2% and 5%. Although people interact with their environment in complex ways, the dimensional provisions in standards documents do not always mirror that intricacy. However, accessibility standards such as ANSI A117.1 have increased in detail over nearly fifty years of development, reflecting improved understanding of how people with disabilities interact with the environment and the building industry's need for compliance guidance. For instance, versions of ANSI A117.1 increased from 5 content pages in 1961 to 103 pages in ICC/ANSI A117.1–2003. Similarly, the first edition had 2 figures; by 1980 it included 52, and the 2003 revision contains 130. Since 1961, ANSI A117.1 has become ICC/ANSI A117.1–2003, adding sections on assembly areas, passenger loading areas, storage, and dwelling units, among others.¹⁵³ While accessibility reference documents address a number of features within buildings in increasing detail, site features (such as pathways) have not received equivalent attention.

Relevant to our purposes here, despite expansion of ANSI A117.1, provisions for maximum pathway cross slopes of 2% and maximum running slopes of 5% have been in place for decades; moreover, these two requirements now are in code and standards documents worldwide.¹⁵⁴ The original 1961 ANSI A117.1 included a 5% running slope limit for exterior

pathways.¹⁵⁵ The provisions for 2% cross slope limits were first included in the 1980 ANSI A117.1. These technical provisions for running and cross slopes along an accessible route are maintained in ANSI A117.1–1986 (found in 4.3.7 Slope), 1:20 and 1:50 for running and cross slope, respectively,¹⁵⁶ and in ANSI A117.1 revisions through the current 2003 edition.

Note that ICC/ANSI A117.1–2003 diverges slightly from a 1:50 (2%) cross slope provision, but in a manner that acknowledges and aligns with typical industry practice and custom. It states a maximum allowed cross slope of 1:48 (2.08%—not a meaningful slope change).¹⁵⁷ That is, a 1:48 ratio conforms to the standard American measurement system in that 1:48 translates to a quarter-inch rise over one foot of run. Understanding this minor exception, the same or similar requirements are found in standards such as the 1994 *ADA Standards for Accessible Design*.¹⁵⁸ They remain in the revised 2004 *ADA/ABA Guidelines*.¹⁵⁹ Overall, despite their durability and ubiquity, these two slope provisions have received little systematic study¹⁶⁰ and minimal attention in standards development.

In addition, rather than having a basis in ergonomic research, the inception of the 2% cross slope has been influenced by nonergonomic information—specifically by concerns of water drainage. All exterior flat work (e.g., concrete or asphalt surfaces for walking and motor vehicles) needs to prevent pooling water. Allowing water to drain off pathways and sidewalks helps maintain safer pathways and reduces degradation by preventing formation of algae and icy patches. Given water flow problems that a truly no-slope (0%) condition would cause, drainage must be part of the design and result.

To prevent ground water from infiltrating structures, it needs to flow away from buildings and toward swales and drains. The ANSI A117.1 committee lacked findings for cross slope limits prior to 1980 to include in the deliberations about creating a maximum allowable cross slope with ease of use as an objective. Our research interviews suggest that, lacking other data, water shedding was a prime reason for the ANSI A117.1 committee establishing the 2% maximum pathway cross slope that appeared in the 1980 ANSI A117.1 for the first time.¹⁶¹ A 2% cross slope was thought to be acceptable to allow an exterior flat surface to shed and drain water. Thus, 2% was selected as the maximum allowable cross slope for accessibility purposes. The lack of ergonomic evidence supporting the 2% cross slope, however, as well as a lack of

development and detailing compared to other requirements warrant renewed assessment of pathway cross slopes.

As further evidence of the research needs in the site area, the Access Board has funded new research at the University of Pittsburgh on cross slopes, though the findings have not yet been published. The Board's position and our analysis of prior research in this area appear consistent: the Board notes "while studies show that cross slopes make wheelchair travel more difficult, there was little consensus on methods or protocols for measuring these effects. Further, ... the measures used in most studies, such as energy consumption and perceived effort, cannot fully assess the complex effects of cross slope."¹⁶²

As mentioned, site slope requirements are similar in such documents as the *ADA Standards for Accessible Design* and the FHAA safe harbors. Yet site accessibility has been considered one of the most challenging areas of built environment standards development for years. The difficulty in addressing site accessibility is evidenced by the work of the Access Board on new public rights-of-way accessibility guidelines intended to address these issues, otherwise not well-handled in conventional standards. The Access Board work began in 1992, and as of the date of this report, has not been completed. Additional evidence of site accessibility challenges appears in a special 2007 report by the Public Rights-of-Way Advisory Committee,¹⁶³ which noted, "ADA standards are not easily applicable to sidewalks, street crossings, and related pedestrian facilities in the public rights-of-way."¹⁶⁴ The committee asserts there is a need to address issues "in a more specific way."¹⁶⁵ This view reflects difficulties in developing manageable policy for site provisions across variable outdoor environments.

1. Site Tolerances

Balancing usability of pathways, successful site drainage, and compliance with site slope provisions is a multifaceted task involving site analysis, industry trades, and construction supervision.¹⁶⁶ Establishing and maintaining adequate drainage on sites and pathways is a priority for the benefit and safety of all users. A pathway cross slope of 2% and running slope of 5% may be shown in construction drawings and be correct when the certificate of occupancy is issued, indicating compliance has been met. Due to challenges with factors outlined above, however, minor variations may exist at project completion. Moreover, maintaining compliant pathway slopes over time is challenged by the variability of site conditions, soil composition, and

construction technology and processes (e.g., precision of drawings and specifications).¹⁶⁷ Slopes change over time because of factors such as frost, erosion, and tree roots.

Our interviews with owners and property managers reveal they typically remedy obvious pathway problems such as uneven slabs with an abrupt vertical level change.¹⁶⁸ Minor slope changes may not result in a shift that creates tripping hazards or drainage problems. Yet these slight changes in slope over a given length may render a pathway technically noncompliant.¹⁶⁹ The extent to which technical noncompliance in cross and running slopes affects usability is discussed later in this report.

As a general matter, the concept of usability relates to design or construction tolerances. Tolerances, often called variances, are applied to building and construction, such as to guidelines for structural steel construction, masonry, doors, and windows.¹⁷⁰ David Ballast, architect and noted author of numerous books on design, specification and construction, states there are “no industry tolerances for asphalt paving,”¹⁷¹ and site slope tolerances for pedestrian pathways are not part of guidelines such as the American Concrete Institute’s document CI 117-06 (*Specifications for Tolerances for Concrete Construction and Materials and Commentary*).¹⁷² Ballast also states, “There are very few industry standard tolerances for right of way construction.”¹⁷³ There often is confusion and disagreement in part due to overlapping federal and state laws addressing site construction. Recognizing the importance of the issue as well as the problems that exist with site tolerances, the Access Board contracted for a report to address tolerances and standards. Due in 2009, the report has been delayed.

Although relevant sections of the ICC/ANSI A117.1–2003 and the 2004 ADAAG show increasing specificity over prior versions, they do not provide clear guidance for site slope tolerances. A general mention of tolerances is found in ICC/ANSI A117.1–2003: “Dimensions that are not stated as ‘maximum’ or ‘minimum’ are absolute.” However, the statement continues, “All dimensions are subject to conventional industry tolerances.”¹⁷⁴ A similar message is conveyed in ANSI A-117.1–1986.¹⁷⁵ Because of the absence of agreement for tolerances in site construction, these advisories tend to lack practical usefulness.

HUD allows for tolerances for field conditions in certain circumstances such as doorways and countertop width.¹⁷⁶ Researchers similarly acknowledge the need for tolerances in standards to address, for instance, environmental conditions affecting individual performance and

characteristics.¹⁷⁷ However, guidance is limited in construction of accessible elements, features, and environments. Again, the absence of recognized tolerances in the area of site slopes hampers effective compliance.

Considering the monitoring and maintenance challenges in outdoor environments, it is not apparent why certain variations from the 2% and 5% slope maximums should result in compliance violations and require remediation. In addition, as discussed earlier, pathway usability is a function of both running and cross slope. A more nuanced approach to site slope tolerances needs to be developed to consider this relationship and to address usability that may be present when numerically minor departures from technical compliance occur.

Beyond the general consideration of site slope tolerances, relevant authority has addressed limited variations from typical provisions. For example, ICC/ANSI A117.1–2003 and the 2004 *ADA/ABA Guidelines* offer slope exceptions from the standard 1:12 maximum ramp slope. In each document, for short ramps of 3 or 6 inches in length, steeper slopes of up to 1:8 are allowed.¹⁷⁸ While ease of use at these steeper slopes may not be the same as at slopes of 1:12 or greater, the trade-off in certain circumstances was deemed worthwhile. In this example, usability was not undermined in real-world conditions.

Site portions of the relevant documents do not offer a similar approach for pathways and slopes. One limited example is the allowance for the sloped sides of curb ramps, also known as curb cuts (see Figure 2). Curb ramps bridge a change in level or grade—for instance, from a sidewalk to a roadway at a cross walk—to allow passage by those who cannot easily manage stepping off or on a curb. The sloped sides of the curb cut as shown in Figure 2 are allowed to be as steep as 1:10, compared to the 1:12 maximum slope for other “ramped” surfaces including the main sloped surface of the curb cut (also indicated in Figure 2).¹⁷⁹

Figure 2. Alternate Curb Ramp Slopes

(Adapted from ADAAG, 2004)

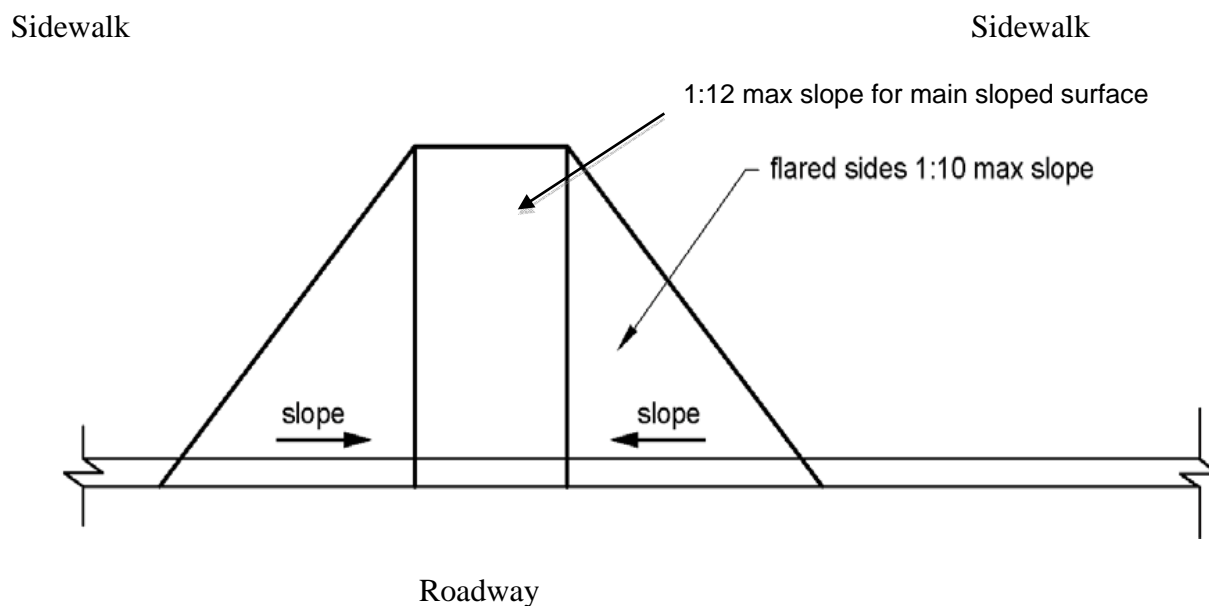

Human factors and environmental conditions may result in construction processes that vary from plans and design specifications in the area of site work. Accordingly, for accessibility purposes, there is a need to establish how much reasonable site slope variation is acceptable and how much variation may trigger remediation. To date, industry, government enforcement agencies, disability groups, and courts recognize no such established accessibility site slope tolerances.¹⁸⁰

2. Illustrative Site Slopes

The Vredenburg and Kockelman studies discussed earlier reinforce the idea that alternative site slopes may be considered. Vredenburg, whose findings are consistent with Kockelman, suggests variations from slope provisions be allowable, in part, because they may be difficult to detect.¹⁸¹ Her study examined running and cross slopes and attempted to evaluate their perceived interaction. Her findings support a tolerance of steeper slopes for short distances, a meaningful relationship between cross and running slopes, and a meaningful relationship between slope, effort, and distance traveled. She concluded cross slopes greater than 2% may be considered but should be limited to 5% when running slope reaches 5%.¹⁸² These conclusions reinforce our view that variances in cross slopes should be considered, in part, as a function of length of pathway and degree of running slope encountered.

The central point is that at low slopes the interaction between running and cross slopes is ameliorative; that is, lower running slopes make contending with higher cross slopes easier. Likewise, low cross slopes provide an advantage when traveling at higher running slopes.¹⁸³ Note that Vredenburg's findings suggest allowable cross slopes of up to 5%. Taken together, Kockelman's and Vredenburg's findings support alternative site slope standards, and their recommendations suggest starting points for purposes of our review. Thus, in analyzing site slope alternatives, we consider approaches that are usable and that may be accepted by diverse stakeholders, in particular by industry and disability advocacy groups. If applied to existing projects, the site slope alternatives presented next offer variations from current standards. If applied to newly built projects, our recommendations may be valuable if compliance disputes arise.

In Tables 4, 5, and 6, we illustrate usability relationships between running and cross slopes. The tables provide one example of how to apply such relationships to particular circumstances. Across pathway lengths of 6, 20, and 50 feet, the tables show that increasing pathway length necessitates lower running and cross slopes to maintain usability. Rather than inflexible one-dimensional approaches, the templates reveal a complex relationship, intended to preserve usability while allowing for variations that occur in real-world circumstances.

Across all three pathway lengths, we show a maximum running slope of 7% and a maximum cross slope of 3.5%. We suggest usability is achieved with a maximum 3.5% cross slope and 7% running slope over the distances illustrated in the tables below. In Table 4, the shaded areas show that over a 6-foot length of pathway, steeper running and cross slopes are acceptable from a usability point of view (because of the short distance and lower potential inconvenience). Over a 6-foot run of pathway, a cross slope of 3.5% is acceptable when paired with a maximum 6% running slope. At this distance, a 7% running slope is acceptable in combination with a maximum cross slope of 3%.

Table 4. Illustrative Slopes for 6-Foot Length of Pathway

Running Slope	2%	3%	4%	5%	6%	7%
Cross Slope						
2.0 %						
2.5 %						
3.0 %						
3.5 %						

The shaded areas in Tables 5 and 6 indicate more-restricted running and cross slopes. Thus, over a 20-foot span (Table 5), a 6.5% running slope is acceptable with a 2% cross slope. For a 50-foot pathway (Table 6), a running slope is limited to 6% with a cross slope of 2%.

Table 5. Illustrative Slopes for 20-Foot Length of Pathway

Running Slope	2%	3%	4%	5%	6%	6.5%
Cross Slope						
2.0 %						
2.5%						
3.0 %						
3.5%						

Table 6. Illustrative Slopes for 50-Foot Length of Pathway

Running Slope	2%	3%	4%	5%	6%
Cross Slope					
2.0 %					
2.5%					
3.0 %					
3.5%					

ACCESSIBILITY STANDARDS FOR MULTIFAMILY HOUSING

Tables 4, 5, and 6 provide an illustrative template for accessible cross and running slope options for a variety of pathway distances. In Appendix 6, we review several settlement agreements in which some negotiated results for slopes exceed current provisions, while others track the standards. One settlement, for instance, accepted running slopes well beyond the 5% limit found in most safe harbors. Another settlement allowed a cross slope of 4%, nearly double the 2% standard, but limited running slopes to 5.25%, only slightly steeper than the 5% running slope limit found in fair housing safe harbors. Although these parameters do not conform exactly to the ranges we illustrate in Tables 4, 5, and 6, they similarly extend running ramp slope provisions covered in the accessibility standards from 5% to 8.33% and beyond.

When considering the slopes illustrated in Tables 4, 5, and 6, it also may be noted the settlements reviewed in Appendix 6 adopted ramp-like provisions in some circumstances, such as the provision of handrails and limitation of pathway runs to no more than 30 feet. This effectively provides the option of treating these surfaces as ramps. Overall, and consistent with our interview findings, such informal practices and negotiated agreements allow for site slope tolerances, in some circumstances with running slopes of 5.25% or 5.5% without triggering remediation.¹⁸⁴ The illustrative templates for site slopes presented in Tables 4, 5, and 6 may be considered for the circumstances identified over specific distances, and in light of the relationship between cross and running slope.

In sum, recent scientific evidence and some negotiated settlements document usability for cross slopes and running slopes beyond 2% and 5%, particularly when they are considered together.

B. Kitchens, Bathrooms, and Environmental Controls

Accessibility standards development for kitchens, bathrooms, and environmental controls also is hampered by the lack of definitive research data.¹⁸⁵ Unit interior provisions in these areas have remained largely unchanged, and detail and specificity is lacking. D'Souza concluded accessibility standards oversimplify reach ranges and do not accurately represent reach capabilities in the current population.¹⁸⁶ This section reviews unit interior provisions, with a focus on reach and centering provisions in kitchens and bathrooms, and environmental control locations.

Recent standards development in this area shows an uneven pattern. For example, later versions of ANSI A117.1 show more reach range detail than earlier versions. ANSI A117.1–1986 has two illustrations for side reach. ICC/ANSI A117.1–2003 has three illustrations for side reach (see Figure 3 and Figure 4). The addition of illustration (a) in Figure 3 reveals greater detail in side reach over an obstruction. The only significant alteration to the dimensions is seen by a more restricted reach range for high and low side reach limits. Compare Figure 5 (an earlier version of a side reach dimension similar to the 1986 ANSI A117.1) with Figure 4 illustrating the change from fifty-four inches (high reach) and nine inches (low reach) in the earlier version, to forty-eight inches and fifteen inches in the 2003 version, respectively.¹⁸⁷ Note: the illustrations used in Figures 3 through 5 are taken from the ADAAG (2004) and the *ADA Standards for Accessible Design* (1994) because these illustrations are identical to the ANSI for which they are being compared and the ANSI illustrations are unavailable due to copyright restrictions.¹⁸⁸

Figure 3. Obstructed Side Reach

(ADAAG, 2004)

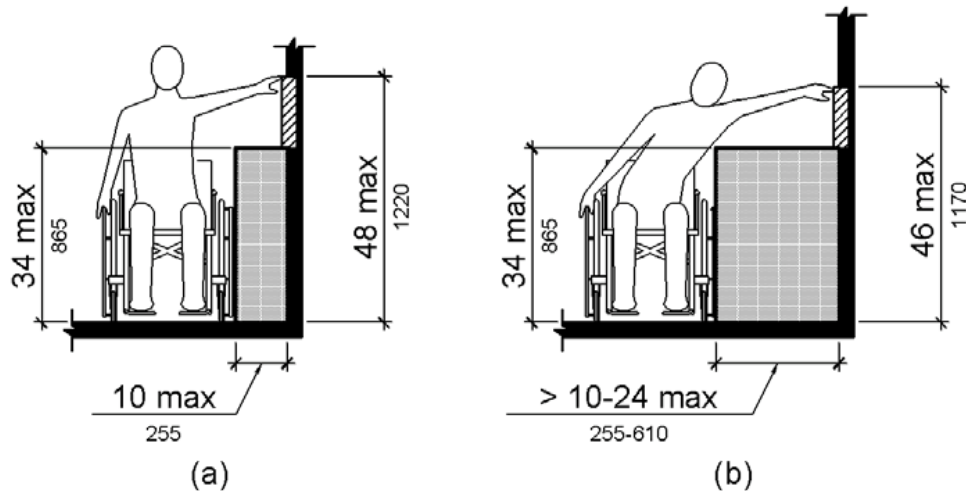

Figure 4. Current Side Reach Dimensions

(ADAAG, 2004)

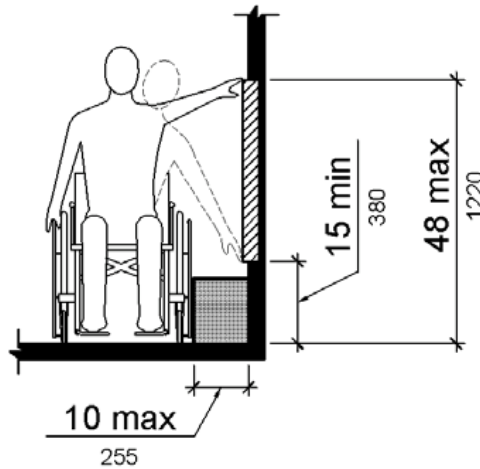
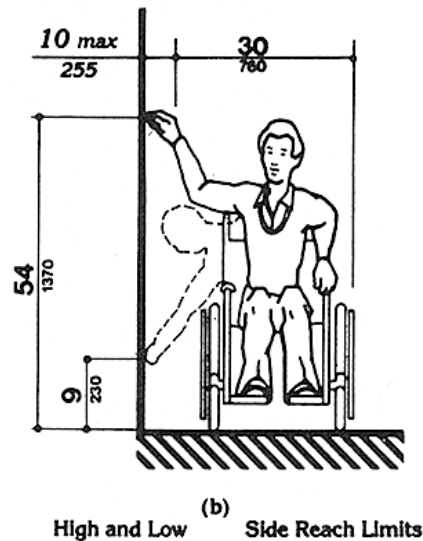

Figure 5. Less-Restrictive Side Reach Dimensions

(ADA Standards for Accessible Design, 1994)



To a limited degree, standards recognize tolerances in structure design and construction. Dimensions illustrated in ICC/ANSI A117.1–2003 (reflected in changes in the 2004 *ADA/ABA Guidelines*) show balance between ergonomic needs and real-world circumstances when compared to earlier standards.¹⁸⁹

Centering, a common mechanism in construction drawings, facilitates the location of fixtures, windows, doors, and other architectural features (whose outside dimensions might vary)

by relying on a common element to all: every toilet, window, etc. has a center. This convention has been used in accessibility requirements for toilet installation. The ADA Standards and Guidelines are examples of positive change in the area of centering that facilitate installation and compliance. The examples below show the move away from single-figure toilet-centering requirement of 18 inches (see Figure 6)¹⁹⁰ and its replacement by a toilet centering range of 16 to 18 inches for wheelchair-accessible water closets (see Figure 7).¹⁹¹

Figure 6. Old Toilet Centering Standard

(ADA Standards for Accessible Design, 1994)

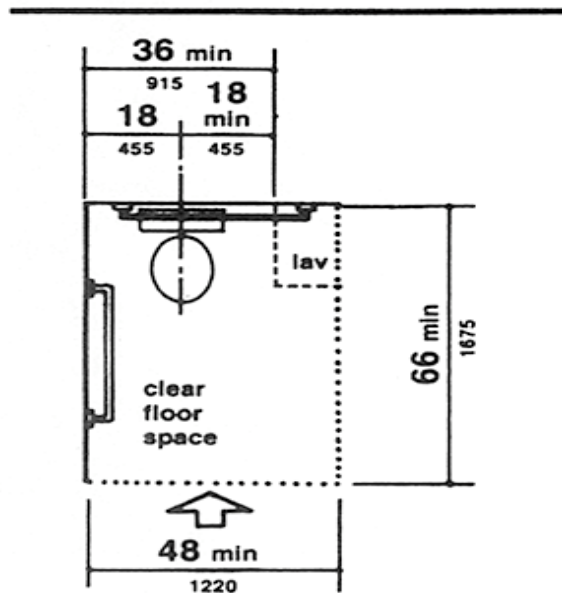
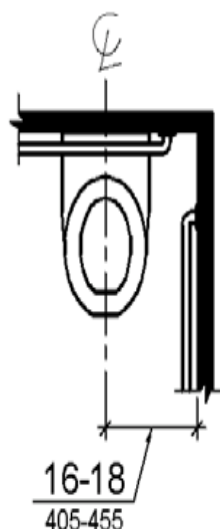

Figure 7. New Toilet Centering Standard

(ADAAG, 2004)



The intent of the toilet centering requirement is to provide positioning and reach distances that enable people who use wheelchairs and other assistive devices to more easily get to, onto, and off of toilets. Reasons for the toilet centering change are illustrative. The change from the absolute requirement of the toilet center line of 18 inches off of a side wall to centering within a 16-to-18-inch range avoids toilet relocation requirements due to minor (e.g., 1-inch) installation variations. Prior tolerances in the accessibility provisions were judged to be too restrictive, while the change offered only a small usability differential.¹⁹² This is an example of a numerically modest change that creates significant improvement in achievable compliance, and responds to the challenges of precise construction locations.

To respond to the lack of anthropometric data for functional reach ranges, D’Souza and colleagues measured the effective functional reach range of persons who use wheelchairs by breaking their near environment into regions and recording the percentage of subjects who could reach each region.¹⁹³ D’Souza measured “functional reach” by requiring participants to perform a grasping and emptying task at the limits of their reach. This is important because it presents a realistic assessment of daily tasks rather than the less-certain assessment of reach to a particular point. The scenarios in the research corresponded to unobstructed front reach (as suggested in ICC/ANSI A117.1–2003, Fig. 308.2.1) and unobstructed side reach (as suggested in ICC/ANSI

A117.1–2003, Fig. 308.3.1). We believe similar research is being conducted on obstructed forward and side reaches (e.g., reaching over counters), which represent other use circumstances in interior spaces.¹⁹⁴

D’Souza’s findings reveal a predictable range of “reachability”; that is, more participants were able to reach areas closer to them than farther away. For example, almost all participants (98%) were successful in reaching the closest region to their side reaches. By contrast, only 12% could reach into the region 28 inches (or 8 regions) away.

However, adjacent regions show close percentile results, in some cases with marginal differences. There are adjacent side high reach regions (that straddle the current *ADA/ABA Guidelines* limits) with differences as slight as 2% to 4%. Seven of the eight side reach regions at 47.2 inches display results no more than 4% different when compared to the next higher region (see Figure 8, in which dark dashed lines represent the reach requirements in the *ADA/ABA Guidelines*, 2004), which extends up to 51.1 inches.¹⁹⁵

As this line of research reveals, it is difficult to establish meaningful differences in usability, in this case “reachability,” between many adjacent regions with such minor variations in results. This research indicates that when seated most individuals may extend beyond the side reach limits in most accessibility provisions. Moreover, usability in upper reach ranges may not be diminished significantly by a tolerance from the 48-inch upper limit.

Figure 8. D’Souza Unobstructed Side Reach Research Results

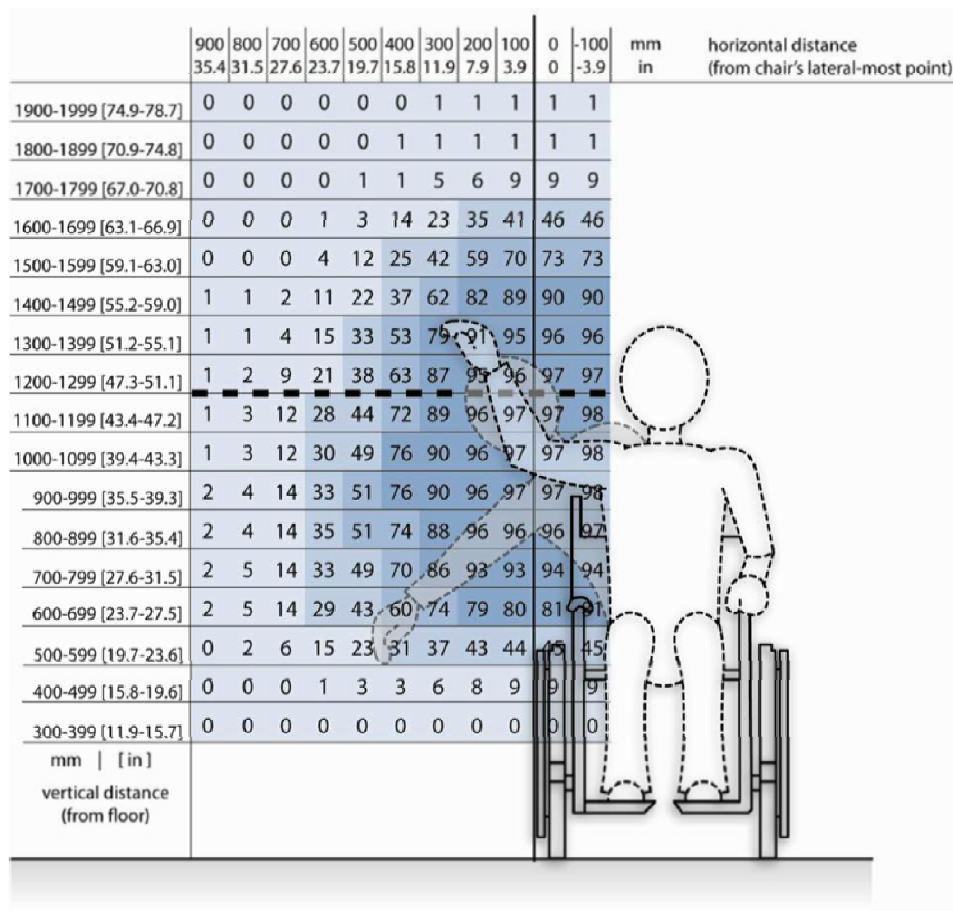

1. Reach and Centering in Kitchens and Bathrooms

Usability of kitchens and bathrooms involves the ability of persons to get to particular locations and reach to perform tasks such as cooking, washing, and dental care. One’s reach range is, of course, affected by space provisions, and is a particularly important factor for those who use mobility devices. ANSI A117.1–2003 addresses this issue by establishing a combination of spaces and accessible routes, including space between walls, fixtures, appliances and cabinets, and knee space. The provision for parallel or perpendicular 30-by-48-inch clear floor space (see ICC/ANSI A117.1, Section 305.3) centered on appliances and fixtures (see ANSI Section 7.3) figures prominently in this calculus.¹⁹⁶

Figure 9 shows one centering scenario where a person using a wheelchair is occupying a 30-by-48-inch clear floor space in a parallel orientation to the stovetop, reaching for a cooking

pan.¹⁹⁷ Ordinary kitchen and bathroom tasks include a need to safely reach stove controls (either on the front or back of ranges), counter tops and other work surfaces, faucets, sinks, medicine cabinets, and refrigerator interiors.

Figure 9. Parallel Centering at a Kitchen Range

(Fair Housing Design Manual, 1998)

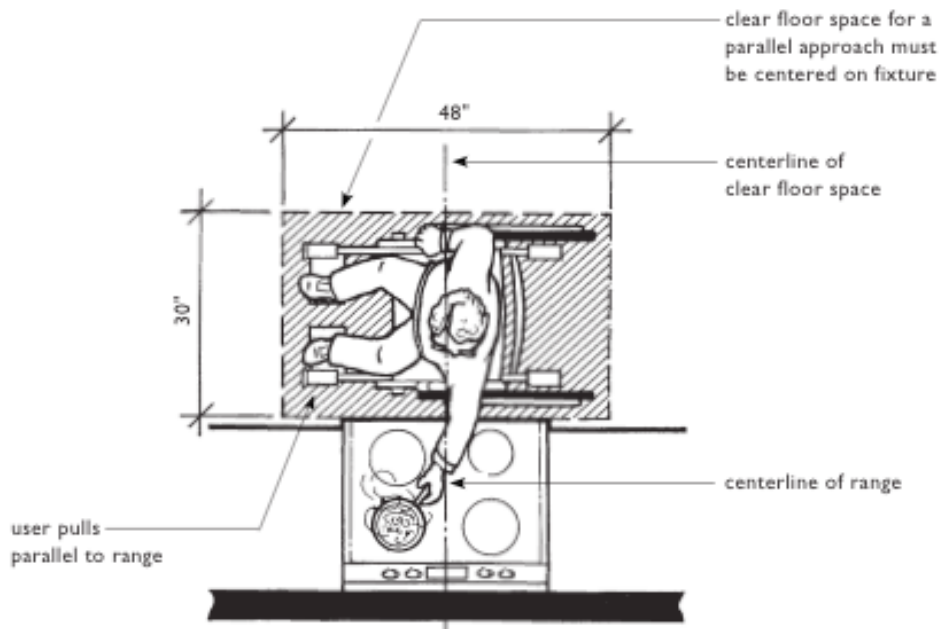

The clear floor space, along with the centering provision and guidance from accessibility standards in obstructed and unobstructed forward and side reach, is intended to enable a person using a wheelchair to reach kitchen or bathroom elements to perform essential and typical tasks.¹⁹⁸ D’Souza’s results show a generalized and graduated range of reachability rather than an all-or-nothing result. This research informs our approach; that is, small shifts in location, in this case centering on appliances and fixtures, may substantially maintain usability.

The lateral region size in D’Souza’s study was 3.9 inches square. If other space provisions are maintained, the impact on usability of a lateral variance in this range from a centering provision should be slight. Reasonable tolerances in kitchens, therefore, may maintain usability and prevent extensive unit rehabilitation (e.g., moving walls or replacing cabinetry). Such centering tolerances may prevent compliance disputes without meaningfully altering the usability of kitchen and bathroom spaces.

a. Kitchen Centering Example

Figure 10 illustrates one scenario with a shift in centering of a few inches, shown by the rectangular overlay that represents the space provision for a person using a wheelchair. The slight shift in the rectangular clear floor space (shown by the altered center line) indicates the small usability impact that may result. Thus, the centering shift in a parallel approach (side approach) in front of a stove is small. If other clearances are maintained, a shift of this dimension should not curtail usability of the range controls or safe access to the stove for most users.

Figure 10. Centering Shift with Parallel Approach

(Fair Housing Design Manual, 1998)

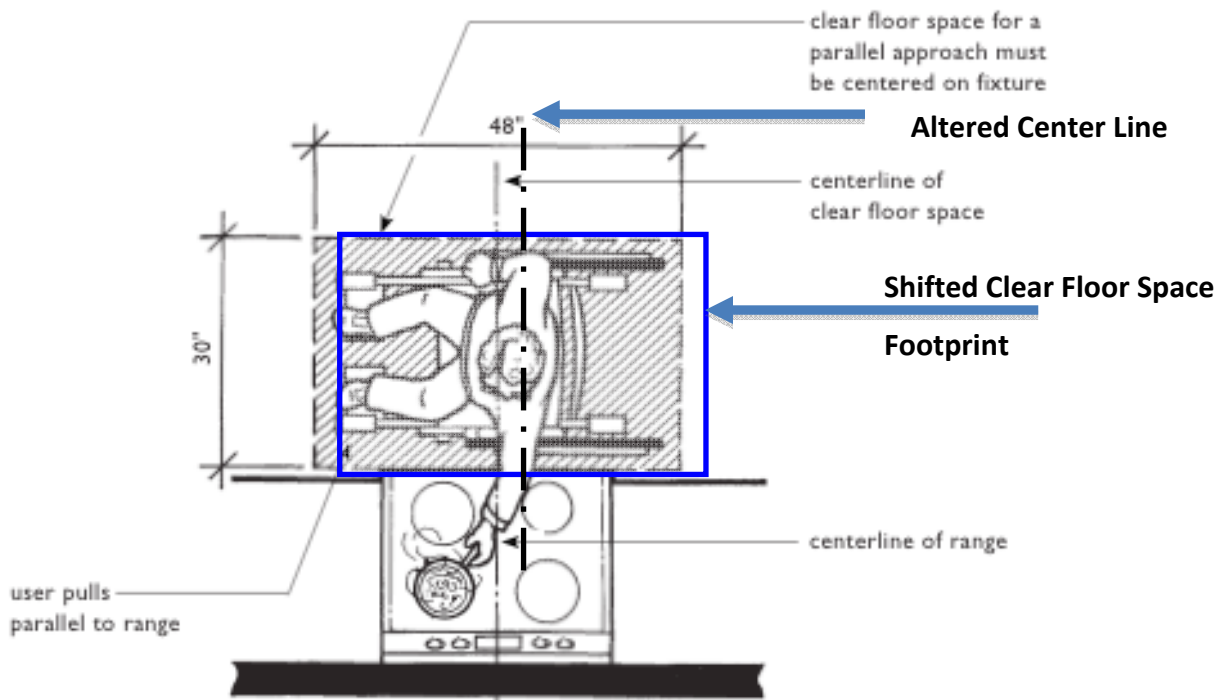

b. Centered Clear Floor Space in Bathroom Example

Figure 11 displays a centering offset by superimposing a lavatory bowl offset a few inches from the original location.¹⁹⁹ An alternative centerline indicates the shift. At this scale, the illustration shows the minor difference of a bowl offset. A shift of this size likely will substantially maintain usability.²⁰⁰

Figure 11. Sample Centering Shift, Lavatory Bowl, Overhead View
(Fair Housing Design Manual, 1998)

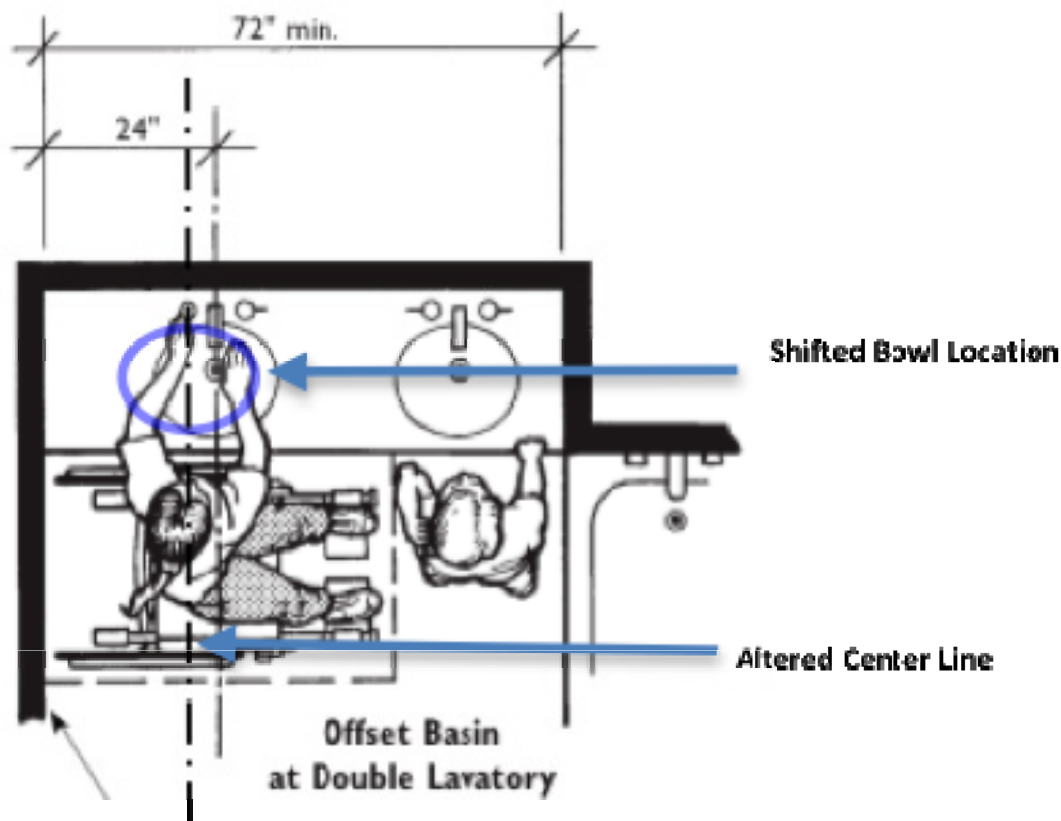

2. Environmental Controls and Usability

Reach ranges play a major role in the mounting heights of environmental controls, such as thermostats, light switches, and electrical outlets. As with other types of anthropometric and ergonomic categories, research in this area that includes people with disabilities is scant. In 2005, the Center for Inclusive Design and Environmental Access (IDeA Center),²⁰¹ directed by Professor Steinfeld, presented a report identifying the need for “revised criteria for reaching from a wheeled mobility device that are more realistic and comparable to everyday tasks.”²⁰²

Accessibility provisions for environmental controls have become more restrictive, reducing high side reach from 54 to 48 inches, as shown in ICC/ANSI A117.1–2003, and raising lower side reach from 9 inches to 15 inches. Figure 12 illustrates the prior provision from the 1994 ADA Standards.²⁰³ Figure 13 shows the new provision, illustrated from ADAAG 2004.²⁰⁴

Figure 12. Less-Restrictive Side Reach Range

(ADA Standards For Accessible Design, 1994)

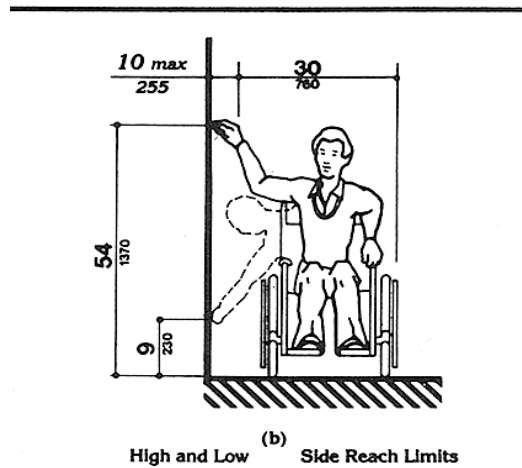
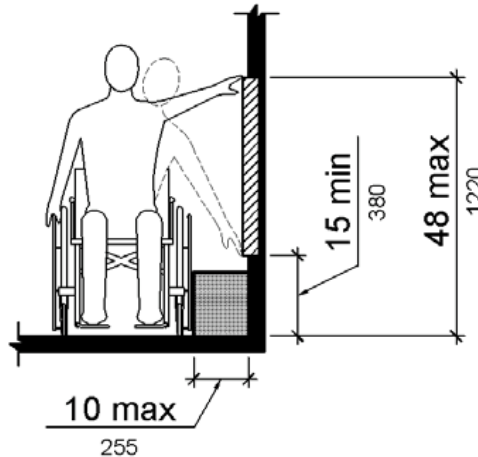

Figure 13. More-Restrictive Side Reach Range

(ADAAG, 2004)



The 2009 D’Souza report highlights potential and actual location usability with important results for high side reach ranges. The marginal differences between the “reachability” of adjacent test regions discussed earlier also apply to environmental control locations (Figure 8 is repeated here as Figure 14 for convenience).²⁰⁵ Two rows of test regions approximately straddle the *ADA/ABA Guidelines* height requirement of 48.0 inches, beginning at a height of 43.4 inches and extending up to 51.1 inches. Examining the lateral high reach results in these adjacent regions reveals no difference, or differences as slight as 2% to 4%, when extended to the lateral limits of the lateral reach provision of 10 inches (see Figure 14). Five of the test regions closest

to the participants share these results, with over 93% all test subjects able to reach into these regions. When examining results that extend beyond 10 inches, the differences between these two rows increase as the number of participants who can reach into these regions declines overall.

Figure 14. D’Souza Unobstructed Side Reach Research Results

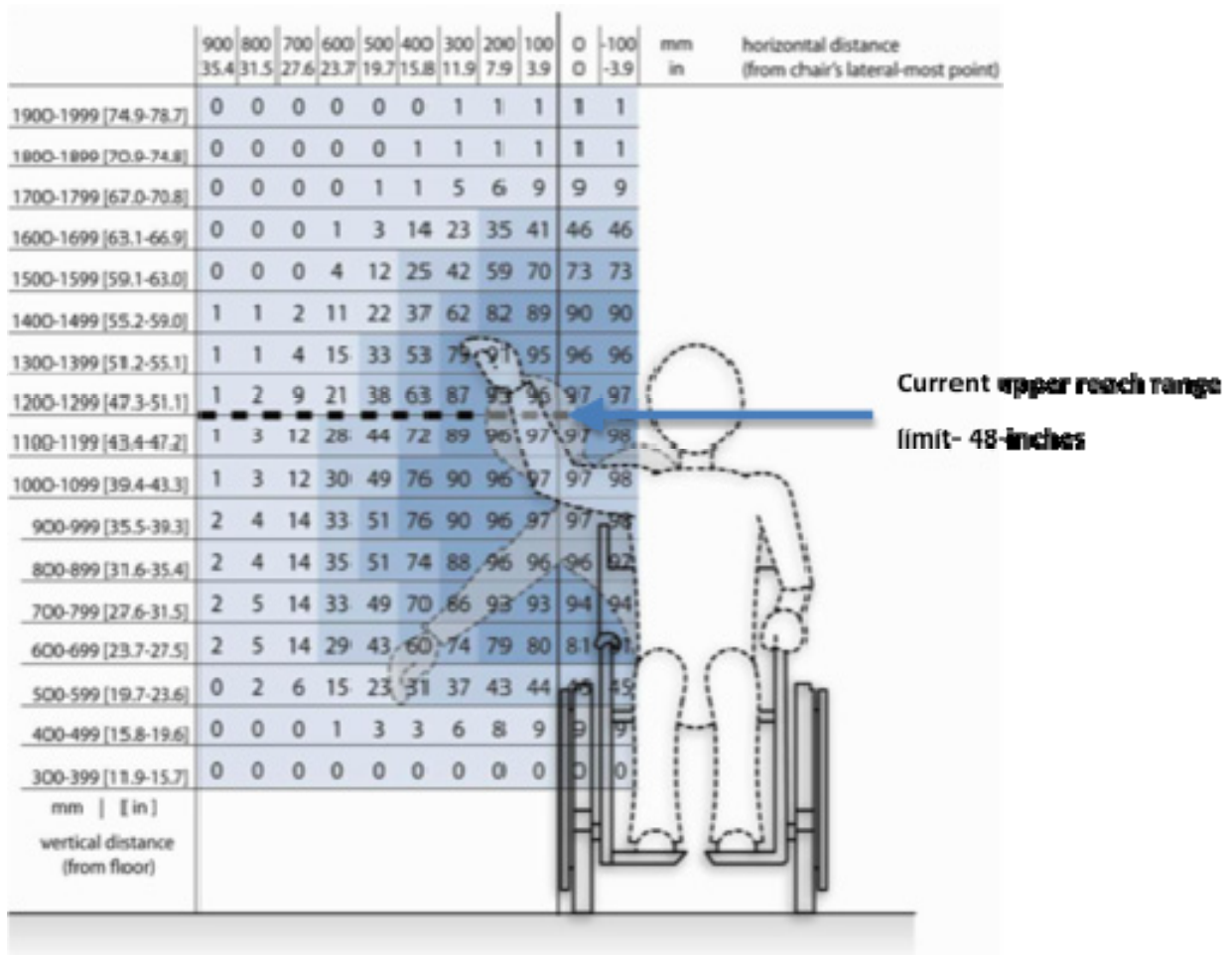

As research shows, it is difficult to establish a wide difference in usability, again in this case “reachability,” between adjacent regions with such modest differences in findings. These factors suggest reasonable variations in the installed height of environmental controls for lateral side reach are acceptable within the limits of a single region. Variation from current provisions may occur without significant deterioration in usability across broad populations. This approach forms the basis for an accepted tolerance in installed heights of operable parts of controls.²⁰⁶

C. Measurement Protocols

Our interviews with industry experts and review of published research and reports reveal that unreliable site measurements often are used for cross and running site slope in exterior pathways.²⁰⁷ Reported problems include too few measurements, inconsistent measurement tool use, and a lack of training in tool use. As a result, many site measurements lack precision, which often leads to compliance disputes.²⁰⁸ The use of informal site measurements results from a lack of standardization in the field. But also this occurs because of a lack of measurement protocols for accurately determining cross and running slopes in exterior pathways.²⁰⁹ In addition, there is a lack of agreement among various stakeholder groups (experts, government, industry) about distances over which slope compliance should be measured and maintained.

We have discussed previously that cross and running site slopes affect usability and safety of pathways, while the impact of some slope differences may be difficult for users to perceive. However, hard-to-detect site slope variations from provisions may be the cause of compliance disputes. This heightens the need for a valid measurement protocol, particularly over varying distances. Accuracy in site measurements may be ensured by using appropriate technology and consistent and reliable approaches to data collection. The tool and use protocols suggested in this section (and detailed in Appendix 7) should be used to reach consistent site condition measurements at the outset of a compliance analysis.

1. Tools and Procedures

Less-troublesome and more-accurate measurements over short and medium distances are possible with available technology. Rather than relying on traditional techniques, field measurements may be made with the most often-used tool to measure slopes over short distances: electronic levels (also known as digital levels or digital inclinometers).²¹⁰

Traditional methods for informal site slope measurements include use of standard spirit levels with rulers, yardsticks, or tape measures and line levels. In addition to the difficulty in creating accurate measurements, these procedures require awkward postures and a steady hand and eye. Professional surveyors use specialized devices such as transits to measure heights and slopes over long distances.²¹¹ Digital levels occupy a space between the technical equipment used by professionals and traditional methods of slope determination. Design and construction professionals increasingly use the levels as well.

The accuracy and ease of use of digital inclinometers make them valuable to professionals and nonprofessionals alike. The availability and affordability of these devices allows them to be used widely as the accepted standard. These levels may be used to measure critical site slopes that often are raised in compliance disputes. Using digital levels appropriately and gathering an adequate amount of data establishes a common framework for evaluating site conditions. Implementing the standard, simple, and effective protocol proposed here will help create an easy-to-confirm fact set about existing conditions on multifamily housing properties. Appendix 7 provides further review of digital levels and their use.

2. Data Collection

Guidance is necessary to establish the number of measurements needed for an accurate picture of usability and compliance for a particular length of pathway. Measurements must establish the slope of the total run and rise of a pathway (measured, for example, from each end of a 20- or 50-foot run of pathway), as well as slope status at interim points along the pathway to ensure ease of use. For accuracy and effective documentation of slope conditions, multiple measurements along the length and width of a pathway are required. However, there are no published guidelines for determining how many points along a pathway to take measurements.

A balance must be achieved between the need for accuracy (gathering enough reliable information to meaningfully draw conclusions about the usability and safety of the pathway) and the time and resources practically available. For example, measurements taken every 6 inches to 2 feet would produce an unnecessary number of data points and take more time than was justified. Still, enough data should be gathered to establish understanding of a pathway's slope along its length, not just over its entire length. The data collected should be considered in the context of the particular and overall slope status of the pathway, as illustrated by our earlier discussion.

Discrete anomalies along a path of travel such as a pothole, divot, depression, or bump may affect the safety and usability of a pathway but shouldn't be part of a slope determination. Adjacent locations that reflect the overall slope of a pathway should be selected as measurement locations instead. An additional factor is that accessible routes are defined as 3-foot-wide pathways, or in some circumstances a 32-inch-wide pathway.²¹² While avoiding a serpentine accessible route along a wider pathway, providing reasonable slopes along a 32-to-36-inch

pathway route width can be considered when measuring a route slope.

Based on an assessment of protocols identified by David Ballast,²¹³ a modified approach yields interval measurements roughly proportional to the length of a particular pathway run. To begin, measurements should be taken approximately a foot from edges and ends. These locations ensure that edge and end paving anomalies, which might be assessed separately, are less likely to be encountered. Under this scheme, the numbers of data points (discrete measurements) are scaled to the length of the pathway, with fewer proportional data points for long pathways when compared to short pathway runs.

Table 7 displays our proposed approach for sample pathway runs of 12, 20, 50, and 100 feet in length. Pathways of increasing width offer more opportunities for users to select an appropriate and safe route, resulting in a comparatively decreasing need for data points. For instance, as shown in Table 7, assuming a 4-foot-wide pathway, for pathways of 12 feet long or less, a minimum of 6 data points should be taken.

Table 7. Sample Data Points, 4-Foot-Wide Pathway

Runs of 12 feet or less	No fewer than 6 data points, evenly spaced
Run of 20 feet	8 data points, evenly spaced
Run of 50 feet	16 data points, evenly spaced
Run of 100 feet	30 data points, evenly spaced

The data point pattern is illustrated in Figure 15, with arrows indicating proposed data collection locations and a data point for every 8 square feet of pathway. A pathway run of 20 feet has 8 data points, producing 1:10 data point ratio. For lengths of 50 feet or more, a data point is gathered for every 13 square feet of pathway.

With this approach, a 50-foot pathway needs 16 data points, while for a run of 100 feet, 30 data points are required. This approach ensures sufficient data are gathered without creating an unnecessary burden on the data collection process. Pathways wider than 6 feet may adopt other strategies, such as collecting additional data points in the middle of the pathway.

Figure 15. Sample Data Point Array, 12-Foot Long Pathway, 4 Feet Wide

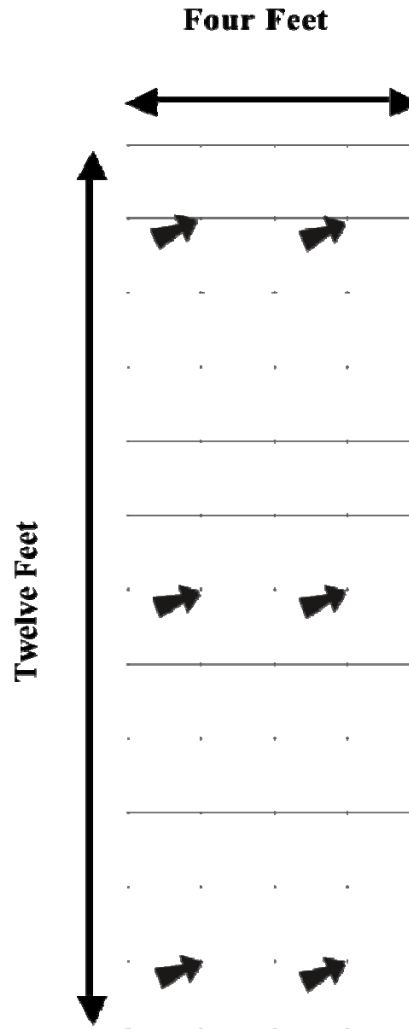

D. Summary

This Part has addressed contested areas of accessibility in multifamily projects: pathway site slopes, reachability and environmental control locations, and kitchen and bathroom centering. We identify gaps in research as applied to standards development and point out studies that suggest alternatives to current standards. The report also has proposed a site slope measurement protocol for accurate data collection.

First, we have presented an illustrative template for alternative site slope parameters to account for variations while ensuring usability. Departures from site slope standards may be acceptable in certain circumstances without affecting usability. Variations from the rigid 2% cross slope and 5% running slope should be acceptable. We suggest a more-flexible approach to

ACCESSIBILITY STANDARDS FOR MULTIFAMILY HOUSING

compliance for pathway site slopes. Our framework also addresses the practicalities of outdoor environments and the shifting of concrete or asphalt over time. Our approach maintains usability while meeting accessibility goals. The aim is a built environment that reflects improved understanding of person and environment relationships as well as the variety of site conditions present in outdoor environments.

In kitchens and bathrooms we suggest centering tolerances that maintain usability and which should not trigger mandatory remediation. Just as in the centering discussion, reach ranges figure prominently in the tolerances that we propose for environmental control location, specifically upper side reach range. We assert that standards may be departed from in these circumstances without affecting usability and safety. This approach is practical for construction and maintenance and provides for ease of use while reducing compliance disputes.

Finally, we suggest a protocol for measurement of pathway site slopes using particular data collection methods. Such measurement and data collection methodologies help establish a common and reliable frame of reference and promote consideration of measurement in the context of pathway characteristics, such as width, length, and overall usability.

IV. Recommendations

This report illustrates the potential for alternative building approaches and procedures that maintain usability and access for persons with disabilities. We analyzed areas of compliance and trends in practice. We reviewed the state of the science to understand its validity and applicability. Our review of research supports greater usability ranges than current accessibility standards allow. We illustrated this point in areas of site slope tolerances and unit interior tolerances for centering and reach. Although scientific evidence shows a range of usability for cross and running slopes beyond 2% and 5% respectively, we do not know the outer limits of this grading without additional research and consideration of pathway length. The report illustrates restrictive tolerances in certain unit interiors may be both unnecessary and impractical. Lastly, we proposed a standardized measurement protocol for assessing site slope compliance.

We recommend alternatives for accessible design features and practice as applied to multifamily housing properties. These recommendations include:

1. The consideration of variable cross and running slopes, beyond 2% for cross slopes and 5% for running slopes for specific site circumstances, which are usable for persons with diverse disabilities.
2. The adoption of appropriate tolerances in centering requirements in kitchens and bathrooms.
3. The adoption of appropriate tolerances in upper reach range environmental control locations.
4. The use of measurement devices and protocols for accurate site condition data.

It is our intent that this review contributes to improved dialogue and research, reasonable practice, and enhanced standards interpretation. The expected result will create and maintain accessible and usable multifamily housing in desired locations for all persons, with and without disabilities.

Appendix 1. Legislative and Standards Development Timeline

- 1961 American National Standards Institute (ANSI).
First voluntary standards for accessible design.
- 1964 Civil Rights Act Of 1964 (P.L. 90-284).
First major civil rights legislation; foundation for future civil rights laws, such as Section 504 of the Rehabilitation Act and Americans with Disabilities Act.
- 1965 Vocational Rehabilitation Amendment Act (P.L. 89-333).
- 1968 Architectural Barriers Act (ABA) (P.L. 90-480).
First law requiring accessibility for people with disabilities in Federal buildings.
- 1968 Fair Housing Act (FHA) (P.L. 90-284, Title VIII).
Prohibits discrimination in housing on the basis of race, religion and national origin.
- 1973 Rehabilitation Act, Section 504 (P.L. 93-112).
Federal civil rights antidiscrimination law for people with disabilities in programs that receive federal funding.
- 1978 Rehabilitation Act, Sections 502 and 504, amended.
- 1980 ANSI publishes revised version of ANSI A117.1, designated ANSI A117.1–1980.
- 1982 Access Board publishes Minimum Guidelines and Requirements for Accessible Design (MGRAD).
- 1984 Federal ABA rule-making agencies publish Uniform Federal Accessibility Standard (UFAS).
- 1986 ANSI publishes revised version of ANSI A117.1, designated ANSI A117.1–1986.
- 1988 Fair Housing Amendments Act (FHAA) (P.L. 100-430).
People with disabilities and children added to 1968 antidiscrimination in housing.

ACCESSIBILITY STANDARDS FOR MULTIFAMILY HOUSING

- 1990 Americans with Disabilities Act (ADA) (P.L. 101-336).
Comprehensive federal civil rights and antidiscrimination law for people with disabilities in public and private settings.
- 1991 Access Board publishes ADA Accessibility Guidelines for Buildings and Facilities (ADAAG).
- 1991 U.S. Departments of Justice and Transportation issue ADA Standards for Accessible Design.
- 1992 ANSI publishes revised version of ANSI A117.1, designated CABO/ANSI A117.1–1992.
- 1994 U.S. Department of Justice issues *ADA Standards for Accessible Design, revised*.
- 1996 Office of Fair Housing and Equal Opportunity, U.S. Department of Housing and Urban Development, *Fair Housing Design Manual*.
- 1998 ANSI publishes revised version of ANSI A117.1, designated CABO/ANSI A117.1–1998.
- 1998 Office of Fair Housing and Equal Opportunity, U.S. Department of Housing and Urban Development, *Fair Housing Design Manual, revised*.
- 2004 International Code Council, American National Standard, Accessible and Usable Buildings and Facilities (named, ICC/ANSI A117.1–2003), revision.
- 2004 Access Board, *Americans with Disabilities Act and Architectural Barriers Act Accessibility Guidelines (ADA/ABA Accessibility Guidelines)*.
- 2008 ICC/ANSI A117.1 revision.²¹⁴

Appendix 2. Fair Housing Safe Harbors

HUD has designated ten accessible design guidelines, standards, and codes as safe harbors for complying with FHAA provisions.²¹⁵

1. *Fair Housing Accessibility Guidelines* (adopted March 6, 1991) (<http://www.hud.gov/offices/fheo/disabilities/fhefhag.cfm>), in conjunction with the June 28, 1994, *Supplement to Notice of Fair Housing Accessibility Guidelines: Questions and Answers About the Guidelines* (<http://www.hud.gov/offices/fheo/disabilities/fhefhasp.cfm>); see 56 FR 9472 (1991).
2. *Fair Housing Act Design Manual* (<http://www.huduser.org/publications/destech/fairhousing.html>); published by HUD in 1996 and updated in 1998.
3. ANSI A117.1–1986, *Accessible and Usable Buildings and Facilities* (available from Global Engineering Documents, 15 Inverness Way East, Englewood, Colorado 90112), in conjunction with the FHAA, HUD’s regulations, and the guidelines for the scoping requirements; see 54 FR 3232 (1989).
4. CABO/ANSI A117.1–1992, *Accessible and Usable Buildings and Facilities* (<http://www.iccsafe.org>), in conjunction with the FHAA, HUD’s regulations, and the guidelines for the scoping requirements; see 65 FR 15740 (2000).
5. ICC/ANSI A117.1–1998, *Accessible and Usable Buildings and Facilities* (<http://www.iccsafe.org>), in conjunction with the FHAA, HUD’s regulations, and the guidelines for the scoping requirements; see 65 FR 15740 (2000).
6. ICC/ANSI A117.1–2003, *Accessible and Usable Buildings and Facilities* (<http://www.iccsafe.org>), in conjunction with the FHAA, HUD’s regulations, and the guidelines for the scoping requirements; see 73 FR 63610 (2008).
7. *2000 ICC Code Requirements for Housing Accessibility* (CRHA), published by the International Code Council (ICC), October 2000 (<http://www.iccsafe.org>) (ICC has issued an errata sheet to the CRHA); see 70 FR 9738 (2005).

ACCESSIBILITY STANDARDS FOR MULTIFAMILY HOUSING

8. *2000 International Building Code*, as amended by the *2001 Supplement to the International Building Code* (2001IBC Supplement); see 70 FR 9738 (2005).
9. *2003 International Building Code*, published by ICC (<http://www.iccsafe.org>), December 2002, with one condition: Effective February 28, 2005, HUD determined the 2003IBC is a safe harbor only under the condition that ICC publish and distribute a statement to jurisdictions and past and future purchasers of the 2003IBC stating, “ICC interprets Section 1104.1, and specifically the Exception to Section 1104.1, to be read together with Section 1107.4, and that the Code requires an accessible pedestrian route from site arrival points to accessible building entrances, unless site impracticality applies. Exception 1 to Section 1107.4 is not applicable to site arrival points for any Type B dwelling units because site impracticality is addressed under Section 1107.7 2.” See 70 FR 9738 (2005).
10. *2006 International Building Code*, published by ICC (<http://www.iccsafe.org>) in January 2006, with a January 31, 2007, erratum to correct the text missing from Section 1107.7.5 and interpreted in accordance with the relevant 2006IBC commentary. See 72 FR 39432 (2007).

Appendix 3. Timeline of Select Studies and Commentary

- 1957 Elmer, C.D., A Study to Determine the Specifications of Wheelchair Ramps. Master's Thesis (Univ. of Iowa).
- 1960 Nugent, T.J., Design of Buildings to Permit Their Use by the Physically Handicapped, in *Proceedings of the 1960 Fall Conference of the Building Research Institute* (Nat'l Academy of Sciences, Washington, DC).
- 1966 Fearn, D., *Architectural Barriers Program of the National Society for Crippled Children and Adults*. Speech presented at the National Research Conference on Architectural Psychology, Park City, UT (ED 036 127).
- 1971 Walter, F., *Four Architectural Movement Studies for the Wheelchair and Ambulant Disabled* (Disabled Living Found.).
- 1978 Allbery, C.F. III & Gressel, M., Accessibility for the Handicapped: The Impact of Section 504 on Architectural and Transportation Barriers, *U. Dayton L. Rev.* 3, 431.
- 1979 Steinfeld, E., Schroeder, S. & Bishop, M., et al., *Accessible Buildings for People with Walking and Reaching Limitations* (ED 184 280).
- 1979 Steinfeld, E., Schroeder, S. & Duncan, J., et al., *Access to the Built Environment: Review of Literature* (ED 184 280).
- 1986 Brubaker, C.E., et al., Effects of Side Slope on Wheelchair Performance, *J. Rehab. Res.* 23, 55.
- 1997 Bruce Bradtmiller & James Annis, *Anthropometry for Persons with Disabilities: Needs for the Twenty-First Century*, Final Report of Task 2 of the "Anthropometric Research Review" (Anthropology Research Project, Inc.) (prepared for the U.S. Access Board).
- 1997 Sanford, J.A., Story, M.F., & Jones, M.L., An Analysis of the Effects of Ramp Slope on People with Mobility Impairments, *Assistive Tech.* 9, 22.
- 2000 Bradtmiller, B., *Anthropometry for Persons with Disabilities: Needs for the Twenty-First Century* (RESNA).
- 2001 Kockelman, K., Zhao, Y. & Blanchard-Zimmerman, C., Meeting the Intent of the ADA in Sidewalk Cross Slope Design, *J. Rehab. Res. & Dev.* 38, 101.
- 2002 Kockelman, K., Heard, L., Kweon Y., et al., Sidewalk Cross Slope Design: Analysis of Accessibility for Persons with Disabilities, *Transportation Research Record* No. 1818: 1.

ACCESSIBILITY STANDARDS FOR MULTIFAMILY HOUSING

- 2002 Steinfeld, E., Lenker, J. & Paquet, V., *The Anthropometrics of Disability* (Ctr. for Inclusive Design & Env'l Access).
- 2004 Steinfeld, E. & Paquet, V., *Space Requirements for Wheeled Mobility: An International Workshop 2* (Ctr. for Inclusive Design & Env'l Access).
- 2005 Steinfeld, E., Maisel, J. & Feathers, D., *Standards and Anthropometry for Wheeled Mobility* (Ctr. for Inclusive Design & Env'l Access).
- 2005 Vredenburg, A.G., & Williams, K., *Evaluating the Effects of Frost Heave on the Feasibility of Compliance with Existing Walkway Accessibility Standards*. Proceedings of the Human Factors and Ergonomics Society, 49th Annual Meeting (2005).
- 2005 Winter, D.A., *Biomechanics and Motor Control of Human Movement* (3d ed.).
- 2006 Kroemer, K.H.E., "Extra-Ordinary" Ergonomics: How to Accommodate Small and Big Persons, The Disabled and Elderly, Expectant Mothers, and Children.
- 2007 The Public Rights of Way Advisory Committee, Special Report: Accessible Public Rights of Way: Planning and Designing for Alterations.
- 2009 D'Souza, C., Steinfeld, E., & Paquet, V., *Functional Reach Abilities of Wheeled Mobility Device Users: Toward Inclusive Design* (Ctr. for Inclusive Design & Env'l Access).
- 2009 Vredenburg, A.G., Hedge, A., Zackowitz I.B., et al., Evaluation of Wheelchair Users' Perceived Sidewalk and Ramp Slope: Effort and Accessibility, *J. Arch'l & Planning Res.* 26, 146.

Appendix 4. Regulatory Documents and Definitions

a. Regulatory Documents

The regulatory, design, and construction sectors refer to three types of documents that guide and control accessibility features in built environment projects under their jurisdiction: guidelines, standards, and codes. The terms are often used interchangeably to mean any or all accessibility regulatory documents. Their descriptive uses may vary from the legal meaning of these terms.

Accessibility Guideline: The term *guidelines* has been adopted at federal and state levels and means a series of recommendations that constitute suggestions rather than mandates or requirements for building design and construction. For example, the term is applied to the ADA accessibility provisions, known as the ADA Accessibility Guidelines, or ADAAG, as issued by the Access Board. Once these or similar provisions are adopted by the DOJ, they achieve enforceable status and become *standards*. Currently, the enforceable standard for the ADA is the *ADA Standards for Accessible Design*, adopted in 1994. The Access Board issued new guidelines in 2004²¹⁶ that await adoption by DOJ. HUD published the *Fair Housing Accessibility Guidelines* to accompany the 1988 FHAA to offer guidance for complying with the act regarding covered multifamily housing.²¹⁷

Accessibility Standard: In addition to the use of the term *standard* applied to ADA provisions mentioned above, the field of accessible design applies the term to the voluntary consensus standards²¹⁸ developed by ANSI. When used in an accessibility context, *standard* refers to editions and revisions of ANSI A117.1, now referred to as *Accessible and Usable Buildings and Facilities*.²¹⁹ First developed in 1961, the document was revised in 1971, 1980, 1986, 1992, 1998, and 2003, with the most significant revisions coming in 1980, 1986, and 2003.²²⁰ Almost all other accessibility codes and guidelines refer to ANSI A117.1, use it as a basis, or incorporate it outright (with or without amendments), as do the model codes (see below).

Accessibility Code: As with the other common terms the phrase *accessibility code* is often used informally, its precise meaning understood in context. The common use of the term refers to the portion of a state or local building code that addresses accessibility provisions; that is, a code

legally adopted by a state or municipality and enforced through plan reviews, site inspections, and issuance of building permits.

This term may also mean *model code*, any of several independently and privately developed national model construction codes that may be adopted in whole or in part, amended or not, by a state or municipality as its building code. For example, the International Code Council (ICC) is the author of the *International Building Code* (IBC) that references ANSI A117.1 for technical information. The ability to adopt, or to amend and then adopt, a portion of the IBC may lead to significant variations in building requirements, including accessibility provisions, from place to place.

b. Definitions

Anthropometric Measurement or Physical Anthropometry

The study of measurements and proportions of the human body—height, length of limbs, size of feet, hands, forearms, and head as well as reach ranges—to understand individual physical variation.²²¹

Biomechanics

“Biomechanics of human movement can be defined as the interdiscipline which describes, analyzes, and assesses human movement.”²²²

Ergonomic Research

The measurement of effort in performing particular tasks; also defined as, “the study of people’s efficiency in their working environment.”²²³

Appendix 5. Methodology Guide

We conducted a series of structured interviews and stakeholder focus groups with builders, designers, property managers, architects, attorneys, government officials, and persons with diverse disabilities. These sessions were organized and guided by the following general topics and questions and analyzed for patterns and trends regarding opportunities, concerns, and suggested solutions.

- I. Accessibility Challenges: In which areas of a multifamily housing development do accessibility issues most often arise?
 - A. Access to/on site; for example, route from parking to dwelling units, parking, recreational areas, garbage disposal areas.
 - B. Building or unit entrance, including threshold, door width, and pressure of closer.
 - C. Common and public use areas, including access to a common laundry room, storage area, clubhouse, pool, tennis court, walking trails, and parking; access to mailboxes; route throughout the public spaces and into the clubhouse kitchen.
 - D. Accessible route in and through the dwelling unit. Does the route through the dwelling unit have raised or sunken areas that cannot be reached?
 - E. Inside the unit. Are light switches, outlets, thermostats, and other controls for heating and air-conditioning 48 inches high or lower depending on the presence of an obstruction such as a desk or table?
 - F. In the kitchen. Is there enough maneuvering space? Is there knee space? Can a 48-inch-by-30-inch clear floor space be centered on each appliance?
 - G. In the bathroom. Are walls reinforced for grab bars? Has installation been attempted? Is there a 48-inch-by-30-inch clear floor space outside the swing of the door? Can a clear floor space be centered parallel to the sink basin? If not, is there knee space under the lavatory? Is it necessary to remove the cabinet face or doors to make this available?
 - H. Other.

ACCESSIBILITY STANDARDS FOR MULTIFAMILY HOUSING

II. Impact of Accessibility Challenges

- A. What are the top five accessibility issues that stem from compliance with the FHAA design guidelines?
 - 1. What functional, safety, and use issues do these cause for people? For example:
 - 2. Gaining access to the site
 - 3. Parking
 - 4. Using site amenities
 - 5. Getting to unit
 - 6. Using bathroom and kitchen
 - 7. Other
- B. Which occur most frequently?

III. Character of Accessibility Challenges

- A. What factors contribute to the compliance issues?
- B. Do the issues arise due to differences with the interpretation of the accessibility requirements of the FHAA Guidelines?
 - 1. How does the interpretation of "adaptability" affect compliance issues?
- C. Do the problems arise due to lack of knowledge or expertise? In which areas?
 - 1. Architecture/Design
 - 2. Construction
 - 3. Maintenance
- D. Do the problems arise during tenant-initiated modifications?
- E. Do problems arise because of requests for modifications in particular time periods, such as 1991–1996 or 1997–2009?

ACCESSIBILITY STANDARDS FOR MULTIFAMILY HOUSING

- IV. Solutions for Accessibility and Usability
 - A. What types of solutions have been attempted?
 - B. Which are successful?
 - C. Which are less successful?
 - D. Identify designs and / or developments that have solved accessibility and usability challenges in innovative ways.
 - 1. Do you know of others who would be able to offer insights into innovative accessible design solutions?
- V. Receptiveness to New and Alternative Solutions
 - A. Would you consider new and alternative design solutions that respond to accessibility and usability challenges?
 - B. What factors would convince you of the efficacy of new design or construction choices?

Appendix 6. Settlement Results: Examples

The settlement agreements reviewed are unique products of the circumstances of the properties and nature of the negotiations. Tables 8²²⁴ and 9²²⁵ display site slope agreements reached in three settlements from which data were obtainable.

Table 8. Camden: Partial Consent Decree, 6-Foot Length of Pathway

Running Slope	2%	3%	4%	5%	6%	7%	8%	9%	10%
Cross Slope									
2.0 %									
2.5 %									
3.0 %									

In running and cross slope circumstances to the limits shown in Table 8, the owner or manager of a property has the option to leave the pathway untouched. However, handrails must be added. Over a 6-foot length of pathway, running slopes greater than 10% or cross slopes greater than 3% must be retrofit to full compliance standards. This is notable because 9% and 10% running slopes exceed ramp slope requirements (with maximum slope allowance of 8.33%). This consent decree does not specify remediation required for violations over lengths beyond 6 feet. Over the short distance of 6 feet, this agreement allows relatively steep running slopes and moderate cross slopes.

Table 9. Kettler and Camden: Settlement Agreement and Consent Decree

Running Slope	2%	3%	4%	5%	5.25%
Cross Slope					
2.0 %					
2.5 %					
3.0 %					
4.0 %					

Table 9 applies to pathways of all lengths, reflecting a lack of consideration for distance traveled as a factor in usability. Remediation is not required unless running slopes exceed 5.25% or cross slopes exceed 4%. These figures place limits on running slopes, but allow cross slopes double the maximum allowable by accessibility guidance documents. The allowance requires other characteristics of the pathways to be compliant.

Appendix 7. Measurement Tools and Procedures

Given the 3-to-100-foot site distances typically found in multifamily housing developments, digital levels perform accurately. The near-unanimous opinion of interviewees suggests digital devices are accurate and the easiest and best means to establish site slopes over short to medium distances.²²⁶ Most experts who were consulted prefer a 2-foot-long level.²²⁷ Other levels include 4-foot levels.²²⁸

A 2-foot-long digital level span is effective in adequately accounting for potential variations in walking and rolling surfaces to promote safety and ease of use; for example, the 2-foot span approximates the spans between the four bearing points of a wheelchair or walker. With site measurements requiring precision within 1 to 2 degrees, accuracy is essential, and experts interviewed for this report claim accuracy is within 0.1% to 0.2%. They claim digital levels are easy to use, may be calibrated effectively, and have high inter-tool reliability.²²⁹ Experts agree users need to read and understand the directions for use and need to calibrate the device before each use.²³⁰

Availability, price, and usability of equipment are not barriers to effective site measurements over the short distances that many compliance questions raise. These devices from various manufacturers are available in a range of prices from \$39.99 to \$198.00 (see Figure 16).²³¹ They are battery powered and provide slope and angle readings in digital or analogue readouts in degrees or percent.

The levels may come with audible alerts and laser capability. The use of these devices is common and has progressed enough that digital inclinometers are customized for easier site slope measurements by adding handles and feet.²³² This customization helps avoid bending and allows for timely and effective site measurements.

Figure 16. Standard 2-Foot-Long Digital Inclinometer



Photo Credit Richard Duncan

Rather than using an informal measurement methodology, a more effective approach for obtaining accurate measurements may employ the following protocol:

- ▶ Use a high quality, 2-foot-long device.
- ▶ Follow manufacturer's instructions.
- ▶ Provide adequate training for those taking measurements.
- ▶ Recalibrate devices daily and when banged or dropped.
- ▶ Make a complete record and adequate documentation, with two photographs of each slope measurement, one close-up photograph and one of the measurement in context.
- ▶ Take measurements perpendicular and parallel to a run of travel.

Appendix 8. About the Blanck Group, LLC

The Blanck Group, LLC, is a premier consulting firm with national and international clients specializing in disability law and policy. Formed by Dr. Peter Blanck, the firm draws together an expert team with experience in disability law, policy, and related research, analysis, and litigation support and dispute resolution services. Dr. Blanck has been appointed a court officer by the U.S. Federal courts to mediate complex disability litigation and has provided expert testimony in state and Federal courts as well as in mediation and arbitration. The Blanck Group's team of leading academics, lawyers, information technology professionals, housing and access professionals, and economists provide exemplary client service and expertise to large and small organizations in the United States and abroad. Contact: blanckgroup@gmail.com

Peter Blanck, Ph.D., J.D., President, Blanck Group, LLC

Dr. Blanck is University Professor at Syracuse University. He is Chairman of the Burton Blatt Institute (BBI) at Syracuse University. Blanck has written on the Americans with Disabilities Act (ADA) and related laws and received grants to study disability law and policy. He is a trustee of YAI/National Institute for People with Disabilities Network and is Chairman of the Global Universal Design Commission (GUDC). Blanck received a Juris Doctorate from Stanford University, where he was President of the *Stanford Law Review*, and a Ph.D. from Harvard University. Blanck is a former member of the President's Committee on Employment of People with Disabilities. Prior to teaching, Blanck practiced law at the Washington D.C. firm Covington & Burling and served as law clerk to the late Honorable Carl McGowan of the United States Court of Appeals for the D.C. Circuit. His recent books are *Race, Ethnicity and Disability* (with Logue) (Cambridge University Press, 2010) and *Disability Civil Rights Law and Policy* (with Hill, Siegal & Waterstone) (West, 2d ed., 2009).

Michael Morris, J.D., Consultant to Blanck Group

Mr. Morris, CEO of the Burton Blatt Institute, is known for his twenty-five years advancing employment opportunities for individuals with disabilities at the local, state, and national levels.

ACCESSIBILITY STANDARDS FOR MULTIFAMILY HOUSING

He is former national executive director of United Cerebral Palsy Associations. His research and policy proposals to improve technology assistance and housing for persons with disabilities have been implemented by Congress, and he directs projects that break down barriers to independence, including grants with the Departments of Labor and Health and Human Services, the Social Security Administration, and the National Institute on Disability and Rehabilitation Research. Morris served as legal counsel to the U.S. Senate Small Business Committee and staff to former U.S. Senator Lowell Weicker from Connecticut.

Richard Duncan, MRP, Consultant to Blanck Group

Mr. Duncan has spent nearly twenty-five years in the field of architectural and product accessibility and universal design in residential, public, and transportation environments. He has extensive experience in design, costs, materials, and products in residential and nonresidential settings. His work includes issues of affordable housing, home and repair financing, and transportation accessibility as well as community design for constituencies that include people with disabilities and aging households. He has directed projects including Safe and Accessible Homes for Independence and has won North Carolina's Excellence in Universal Housing Design Award. One of his recent projects, "Affordable and Universal Homes for Independence," assisted homebuilders to improve capacity to produce universal housing. Another project, "Universal Design Homes," developed a demonstration home in Atlantic City. He has participated in the Universal Design Education Online Project, an online resource for learning about and teaching about universal design. His work places Mr. Duncan at the intersection of common practice, private sector interests, individual household problems and challenges, and public policy development. His career has tracked the emergence of community design as a significant element in healthy households and healthy communities.

Mr. Duncan participates in research and design initiatives and has written on accessible and universal design, planning and public health. He is editor of *A Blueprint for Action* and was project director of *Access Boston: Design Guidebook for Barrier Free Access*, the nation's first urban design guideline for accessibility. He is the 2003 recipient of the Icons of the Industry Award from the Senior Housing Council of the National Association of Home Builders. He spent twenty-four years working in two of the nation's preeminent organizations in the field, the

ACCESSIBILITY STANDARDS FOR MULTIFAMILY HOUSING

Adaptive Environments Center in Boston and The Center for Universal Design in North Carolina. He is a graduate of Tufts University and the planning program at Department of City and Regional Planning at the University of North Carolina, Chapel Hill. He is Executive Director of the Housing Works Universal Design Institute.

William N. Myhill, M.Ed., J.D., Consultant to Blanck Group

Mr. Myhill is Director of Legal Research and Writing for the Burton Blatt Institute (BBI), where he oversees disability law and policy research initiatives. With over twenty years of professional experience in law and education, he has collaborated with and provided services for diverse individuals with disabilities through extensive research, teaching, and advocacy. Mr. Myhill holds appointments as Adjunct Professor of Law at Syracuse University (SU) and Faculty Associate at the Center on Digital Literacy, SU iSchool. He has published law review and peer reviewed articles, book chapters, and commissioned reports on a wide range of disability issues.

Endnotes

¹ Of the 134 cases we analyzed, 109 arose since 2001. *See* Part I for a discussion of the cases collected and analyzed.

² Total complaints on the basis of disability increased from 3,766 to 4,675, accounting for 41% of all complaints in 2005 and 44% in 2008, respectively. U.S. Dep’t of Hous. & Urban Dev., *The State of Fair Housing: FY 2008, Annual Report on Fair Housing* 3 (2009).

³ There were 333 complaints in 2005 (4% of the total), decreasing to 176 in 2008 (2% of the total) for alleged design and construction violations. *Id.* at 6

⁴ *See generally*, Appendix 1 (Legislative and Standards Development Timeline), Appendix 2 (Fair Housing Safe Harbors Timeline); Appendix 4 (Regulatory Documents and Definitions).

⁵ Pub. L. 90-284, 82 Stat. 73 (Apr. 11, 1968).

⁶ Pub. L. 100-430, 102 Stat. 1619-39 (Sept. 13, 1988); 42 U.S.C. §§ 3603-06 (2006). For a recent discussion, see National Council on Disability (NCD), *The State of Housing in America in the 21st Century: A Disability Perspective*, available at www.ncd.gov (Jan. 19, 2010) (discussing recommendations to improve housing opportunities for people with disabilities, for instance, the need for accessible home modifications such as ramps, information to assist stakeholders better understand regulations, and changes within HUD to prevent and mitigate discrimination such as by training on consistent interpretation of laws, standards, and requirements for accessibility).

⁷ 42 U.S.C. §§ 3612-14.

⁸ Fair Housing; Implementation of the Fair Housing Amendments Act of 1988, 53 Fed. Reg. 44,992, 45,030–31 (Nov. 7, 1988) (to be codified at [24 C.F.R. § 100.205](#)).

⁹ *Compare* 42 U.S.C. §§ 3604(f)(3)(C) & 3604(f)(4) (2006) (FHAA statutory accessible design and construction mandate), with 24 C.F.R. §§ 100.205(c) & (e) (2007) (FHAA regulatory accessible design and construction mandate).

¹⁰ Final Fair Housing Accessibility Guidelines, 56 Fed. Reg. 9472, 9499–9512 (Mar. 6, 1991); Kimberly Paarlberg, 2006 IBC “Safe Harbor” Update, *Bldg. Safety J.*, at 31 (June 2007), available at <http://www.mrsc.org/artdocmisc/SafeHarborUpdate.pdf>.

¹¹ Eric A. Berg & Bill Hecker, Accessibility Law—An Ounce of Prevention Is Worth a Pound of Cure, 28 *Construction Lawyer* 5, 8 (2008).

¹² 28 C.F.R §§ 36.101, 36.201, & pt. 36 app. A (ADAAG § 4.6–4.7) (2009). We cite here generally to the current codification of the ADAAGs (as well as the ADA Standards for Accessible Design), though individual cases when citing to this provision presumably are referencing the ADAAGs as they existed at the time the opinion or decree was written.

¹³ For the purposes of this report, an “alleged” violation includes cases where determination of the violation is pending; and “concluded” violations include those held in violation of applicable law by a court of law or administrative law judge, and those to which a party to a consent decree or order, or settlement, has agreed to remedy without admitting liability. We decided to include both types of cases in the analysis because the distribution of the types of accessibility issues in the pending cases closely paralleled those of the concluded cases, and the pending cases raised far fewer accessibility issues than the concluded cases. Also included among these cases are those with claims on which the defendant prevailed.

¹⁴ A review of the FHAA’s legislative history suggests the accessibility requirements were to be “modest,” promoting “adaptable” design, resulting in features that “do not look unusual” or vary

substantially from conventional housing, do not add significant costs, and do not necessarily increase the size of standard kitchens and bathrooms. H.R. Rep. No. 100-711, at 18 & 26-27, 1988 U.S.C.C.A.N. at 2179 & 2187-88.

¹⁵ Timothy J. Nugent, Design of Buildings to Permit Their Use by the Physically Handicapped, in *Proceedings of the 1960 Fall Conference of the Building Research Institute*, 54-56 (Nat'l Academy of Sciences, Washington, D.C. 1960).

¹⁶ Terrell Star, Pioneer for Equality: Nugent Engineered Access for Students in Higher Education, *Daily Illini*, Apr. 28, 2009, <http://www.dailyillini.com/news/campus/2009/04/28/pioneer-for-equality> (last visited Nov. 11, 2009). Nugent created a wheelchair athletic program including the National Wheelchair Basketball Tournament and the first wheelchair accessible bus system. *Id.*

¹⁷ Donald Fearn, *Architectural Barriers Program of the National Society for Crippled Children and Adults*, at 26-b1. Speech presented at the National Research Conference on Architectural Psychology, Park City, UT (1966). ED 036 127.

¹⁸ Nugent, *supra* note 15, at 56.

¹⁹ ANSI adopted the current name in 1969. ANSI, *ANSI: Historical Overview*, http://www.ansi.org/about_ansi/introduction/history.aspx?menuid=1 (last visited Nov. 11, 2009).

²⁰ Nugent, *supra* note 15, at 56. Nugent was funded by the National Society for Crippled Children and Adults (later becoming Easter Seals) to raise awareness, and had an influential role in the development of ANSI. Fearn, *supra* note 17, at 26-b1 to 26-b2.

²¹ Nugent, *supra* note 15, at 54.

²² *Id.* at 58. Broadly speaking, these included site planning, entrances, steps and surface materials, sidewalks and parking areas, doorways, hardware, windows, corridors, restrooms, controls, precautions, and emergency warning signals, among others. *Id.* at 60-66 (reprinting the work plan).

²³ *Id.* at 54.

²⁴ *Id.*; Meredith Gall et al., *Educational Research* 220 (8th ed. 2007).

²⁵ Edward Steinfeld, Steven Schroeder, James Duncan, et al., *Access to the Built Environment: Review of Literature* 99 (1979) (ED 184 280) [hereinafter "Steinfeld, *Review of Literature*"].

²⁶ *Id.* at 102. "Anthropometry is the measurement and analysis of body characteristics, including stature, sizes of body parts and the space in which the body functions, e.g. reach limits and clearances for movement." Edward Steinfeld, James Lenker & Victor Paquet, *The Anthropometrics of Disability* 11 (Ctr. for Inclusive Design & Env'l Access 2002) [hereinafter "Steinfeld, *Anthropometrics of Disability*"].

²⁷ Steinfeld, *Review of Literature*, *supra* note 25, at 106.

²⁸ *Id.* at 115.

²⁹ Steinfeld, *Anthropometrics of Disability*, *supra* note 26, at 11.

³⁰ *See generally*, Proceedings of the 1960 Fall Conference of the Building Research Inst. 1-25 (Nat'l Academy of Sciences, Washington, D.C. 1960) (discussions by Morris Kaplan, Technical Director of the Consumer Union of the United States; Benjamin Handler, Professor of Planning in the Department of Architecture, University of Michigan; Neil A. Connor, Director of the Architectural Standards Division, Federal Housing Administration; and Albert G. Matamoros, General Manager of Economic and Marketing Research, Armstrong Cork, Co.).

³¹ Nugent, *supra* note 15, at 53-59.

³² Am. Nat'l Standards Inst., Inc., ANSI A117.1-1961

³³ Nugent, *supra* note 15, at 58.

³⁴ Nat'l Comm. on Architectural Barriers to Rehab. of the Handicapped, Design for All Americans 36 (1967) ED 026786 (34 by statute, 5 by resolution, 3 by executive order, and 2 in the building code) [hereinafter "Design for All Americans"].

³⁵ *Id.* at 5.

³⁶ *Id.*

³⁷ U.S. Access Bd., *History of the Access Board*, <http://www.access-board.gov/about/history.htm> (last visited Nov. 11, 2009).

³⁸ See Vocational Rehabilitation Act Amendments of 1965, Pub. L. No. 89-333, § 15(a)-(b), 79 Stat. 1282 (1965) (current version at 29 U.S.C.A. §§ 701 *et seq.* (2006)); Design for All Americans, *supra* note 34, at 3.

³⁹ Accessibility of Public Buildings to the Handicapped: Hearing on S. 222 Before the S. Subcomm. on Public Buildings and Grounds on S. 222, 90th Cong. 88-89 (1967) (statement of Edward H. Noakes, Director, Architectural Barriers, American Institute of Architects).

⁴⁰ Design for All Americans, *supra* note 34, at 8-9.

⁴¹ *Id.* at 11.

⁴² *Id.*

⁴³ *Id.* at 12.

⁴⁴ U.S. Access Bd., *supra* note 37.

⁴⁵ U.S. Access Bd., *Uniform Federal Accessibility Standards (UFAS): Introduction*, <http://www.access-board.gov/ufas/ufas-html/ufas.htm> (last visited Nov. 11, 2009) (codified at 41 C.F.R. subpt. 101-19.6, App. A).

⁴⁶ Timothy Creagan, *Establishing Accessibility Standards Through Legislation and Regulation: The Experience of the United States Access Board*, in *The Accessibility Imperative: Implications of the Convention on the Rights of Persons with Disabilities for Information and Communication Technologies* 181 (G3ict 2007).

⁴⁷ *Id.*

⁴⁸ Charles Fred Allbery, III & Michele Gressel, Accessibility for the Handicapped: The Impact of Section 504 on Architectural and Transportation Barriers, 3 *U. Dayton L. Rev.* 431, 435 (1978).

⁴⁹ Steinfeld, *Review of Literature*, *supra* note 25, at 105-06, 120-21.

⁵⁰ *Id.* at 98-128.

⁵¹ *Id.* at 100.

⁵² *Id.* at 105.

⁵³ *Id.* at 106.

⁵⁴ *Id.* at 107 & 111 (citing K.F.H. Murrell, *Ergonomics* (Chapman & Hall, 1965); Felix Walter, *Four Architectural Movement Studies for the Wheelchair and Ambulant Disabled* (Disabled Living Found. 1971)). The study of biomechanics and the field of ergonomics are similar with methodologies and findings that significantly overlap. See Appendix 4 (definitions).

⁵⁵ Steinfeld, *Review of Literature*, *supra* note 27, at 115 (citing Alexander Kira, *The Bathroom* (Ctr. for Housing & Env'l Stud., Cornell Univ., 1966)).

⁵⁶ *Id.* at 120-21 (citing Webb, et al., *Unobtrusive Measures: Nonreactive Research in the Social Sciences* (Rand McNally 1966)).

⁵⁷ *Id.* at 105-11.

⁵⁸ Edward Steinfeld, Steven Schroeder, Marilyn Bishop, et al., *Accessible Buildings for People with Walking and Reaching Limitations* 15-156 (1979). (ED 184 280) [hereinafter “Steinfeld, *Accessible Buildings*”].

⁵⁹ *Id.* at 163 (citing Felix Walter, *Four Architectural Movement Studies for the Wheelchair and Ambulant Disabled* (1971); S. O. Brattgard, Unpublished Research (Univ. of Goteborg, Sweden, 1974); H. E. McCullough & M. B. Farnham, *Space and Design Requirements for Wheelchair Kitchens*, Bull. No. 661 (Coll. of Agric. Extension Serv., 1960)).

⁶⁰ Walter, *supra* note 54.

⁶¹ The rigor of the earlier studies is unclear. Only the published Walter study was available at the time of writing this report.

⁶² Steinfeld, *Accessible Buildings*, *supra* note 58, at 161 (citing Charles D. Elmer, A Study to Determine the Specifications of Wheelchair Ramps, Master’s Thesis (Univ. of Iowa, 1957); Walter, *supra* note 54)).

⁶³ ANSI §§ 4.29-4.30 (1980) *Id.* § 4.34, 4.17-24, 4.7.

⁶⁴ Steinfeld, *Anthropometrics of Disability*, *supra* note 26, at 22.

⁶⁵ Early bills in Congress were formulating what would become the Fair Housing Amendments Act of 1988. *See, e.g.*, Fair Housing Amendments Act. S. 558, 100th Cong., 1st Sess., 133 Cong. Sec. S-2256 (daily ed. Feb. 19, 1987).

⁶⁶ ANSI §§ 4.26-4.27 (1986) (alarms, detectable warnings).

⁶⁷ Clifford E. Brubaker, et al., Effects of Side Slope on Wheelchair Performance, 23 *J. Rehab. Res.* 55, 55 (1986).

⁶⁸ *Id.*

⁶⁹ *Id.* at 56. Drag, or air resistance, refers to when “an object is subjected to a constant driving force . . . but has its motion opposed by a resistive force . . . that always act in a direction opposite to the instantaneous velocity.” A. P. French, *Newtonian Mechanics* 210 (1970).

⁷⁰ Brubaker, et al., *supra* note 67, at 56.

⁷¹ *Id.*

⁷² Steinfeld, *Anthropometrics of Disability*, *supra* note 26, at 15-17; Edward Steinfeld & Victor Paquet, *Space Requirements for Wheeled Mobility: An International Workshop 2* (Ctr. for Inclusive Design & Env’l Access 2004).

⁷³ Bruce Bradtmiller, *Anthropometry for Persons with Disabilities: Needs for the Twenty-First Century* 1-3 (RESNA 2000).

⁷⁴ Steinfeld, *Anthropometrics of Disability*, *supra* note 26, at 33.

⁷⁵ *Id.* at 19.

⁷⁶ *Id.* at 33.

⁷⁷ Bradtmiller, *supra* note 73, at 1.

⁷⁸ *Id.* at 1; Steinfeld, *Anthropometrics of Disability*, *supra* note 26, at 15

⁷⁹ Bruce Bradtmiller & James Annis, *Anthropometry for Persons with Disabilities: Needs for the Twenty-First Century*, Final Report of Task 2 of the “Anthropometric Research Review” (Anthropology Research Project, Inc., 1997) (prepared for the U.S. Access Board).

⁸⁰ *Id.* at 3 & 10.

⁸¹ Steinfeld, *Anthropometrics of Disability*, *supra* note 26, at 17.

⁸² Bradtmiller, *supra* note 73, at 2.

⁸³ Steinfeld, *Anthropometrics of Disability*, *supra* note 26, at 34.

- ⁸⁴ Edward Steinfeld & Victor Paquet, *Space Requirements for Wheeled Mobility: An International Workshop 6 & 8* (Ctr. for Inclusive Design & Env'l Access 2004).
- ⁸⁵ *Id.* at 8-13.
- ⁸⁶ Steinfeld, *Anthropometrics of Disability*, *supra* note 26, at 20.
- ⁸⁷ *Id.* at 34.
- ⁸⁸ Steinfeld & Paquet, *supra* note 72, at 8-13.
- ⁸⁹ Steinfeld, *Anthropometrics of Disability*, *supra* note 26, at 20.
- ⁹⁰ Bradtmiller & Annis, *supra* note 79, at 16.
- ⁹¹ Bradtmiller, *supra* note 73, at 2.
- ⁹² Steinfeld, *Anthropometrics of Disability*, *supra* note 26, at 16.
- ⁹³ Steinfeld et al., *supra* note 84, at 4.
- ⁹⁴ Jon A. Sanford, Molly F. Story, & Michael L. Jones, An Analysis of the Effects of Ramp Slope on People with Mobility Impairments, 9 *Assistive Tech.* 22 (1997) [hereinafter “Sanford, et.al”].
- ⁹⁵ *Id.*
- ⁹⁶ *Id.* at 25.
- ⁹⁷ *Id.* at 24.
- ⁹⁸ *Id.* at 26.
- ⁹⁹ *Id.* at 22.
- ¹⁰⁰ Sanford, et al., *supra* note 94, at 30.
- ¹⁰¹ *Id.* at 28-29. However, those using wheelchairs were afraid of tipping backwards on running slopes greater than 1:12. *Id.* at 30.
- ¹⁰² *Id.* at 28-29.
- ¹⁰³ *Id.* at 22 & 30.
- ¹⁰⁴ *Id.* at 29.
- ¹⁰⁵ Sanford, et al., *supra* note 94, at 29.
- ¹⁰⁶ *Id.*
- ¹⁰⁷ *Id.* at 29-30.
- ¹⁰⁸ These were the 1:10 and 1:8 slopes. *Id.* at 30.
- ¹⁰⁹ *Id.* at 28.
- ¹¹⁰ *Id.* at 33.
- ¹¹¹ Kara Kockelman, Yong Zhao, & Chessie Blanchard-Zimmerman, Meeting the Intent of the ADA in Sidewalk Cross Slope Design, 38 *J. Rehab. Res. & Dev.* 101, 102 (2001) [hereinafter “Kockelman, Meeting the Intent”]; Kara Kockelman, Lydia Heard, Young-Jun Kweon, et al., Sidewalk Cross Slope Design: Analysis of Accessibility for Persons with Disabilities. *Transportation Research Record* No. 1818: 1 (2002) [hereinafter “Kockelman, Sidewalk”].
- ¹¹² Kockelman, Meeting the Intent, *supra* note 111, at 103-04.
- ¹¹³ *Id.* at 105.
- ¹¹⁴ Kockelman, Sidewalk, *supra* note 111, at 108-18.
- ¹¹⁵ *Id.*
- ¹¹⁶ Kockelman, Meeting the Intent, *supra* note 111, at 106-07.
- ¹¹⁷ Kockelman, Sidewalk, *supra* note 111, at 12.
- ¹¹⁸ *Id.* at 13-14 & 16.
- ¹¹⁹ *Id.*
- ¹²⁰ *Id.*

¹²¹ *Id.*

¹²² *Id.* at 14.

¹²³ Kockelman, Sidewalk, *supra* note 111, at 15.

¹²⁴ Alison G. Vredenburgh, Alan Hedge, Ilene B. Zackowitz, et al., Evaluation of Wheelchair Users' Perceived Sidewalk and Ramp Slope: Effort and Accessibility, 26 *J. Arch'l & Planning Res.* 146 (2009).

¹²⁵ *Id.* at 146-147. The participant group included 21 persons without disabilities "who served as surrogate wheelchair users to represent people who might be new users." *Id.* at 146.

¹²⁶ *Id.* at 147-48.

¹²⁷ *Id.* at 147-49.

¹²⁸ *Id.* at 155-156.

¹²⁹ *Id.* at 156-157.

¹³⁰ Vredenburgh, et al., *supra* note 124, at 156-157.

¹³¹ *Id.* at 157.

¹³² Clive D'Souza, Edward Steinfeld, & Victor, Paquet, *Functional Reach Abilities of Wheeled Mobility Device Users: Toward Inclusive Design 5* (Ctr. for Inclusive Design & Env'l Access, 2009).

¹³³ *Id.* at 2.

¹³⁴ *Id.*

¹³⁵ *Id.* at 3.

¹³⁶ *Id.*

¹³⁷ *Id.*

¹³⁸ D'Souza et al., *supra* note 132, at 3.

¹³⁹ D'Souza found only 61% of participants "could reach beyond the anterior-most point of their body or mobility device" at the maximum height established by the ADAAG, for example, to a height of 48 inches at a depth of 20 inches over an obstruction (ADAAG, 308.2.2 Obstructed High Reach). *Id.* The authors suggest that providing greater toe or knee clearance would allow participants to reduce the necessary forward reach distance, and increase the percentage of participants accommodated. *Id.*

¹⁴⁰ Jon A. Sanford, *Bathing Needs of Older Adults with Mobility Disabilities*, Paper Presented at the Anthropometrics of Disability International Workshop (Buffalo, NY, May 31 to June 2, 2001), as cited in Steinfeld, *Anthropometrics of Disability*, *supra* note 26, at 74.

¹⁴¹ *Id.*

¹⁴² U.S. Dep't of Justice, ADA Standards for Accessible Design (Revised 1994) (figure used is the same as referred to in ADAAG for study).

¹⁴³ Sanford, *supra* note 140, as cited in Steinfeld, *Anthropometrics of Disability*, *supra* note 26, at 21.

¹⁴⁴ Kockelman, Meeting the Intent, *supra* note 111, at 10; D'Souza, et al., *supra* note 132, at 1-2.

¹⁴⁵ Vredenburgh, et al., *supra* note 124, at 157.

¹⁴⁶ Kockelman, Meeting the Intent, *supra* note 111, at 109.

¹⁴⁷ Vredenburgh, et al., *supra* note 124, at 157.

¹⁴⁸ 28 C.F.R. pt. 36 § 4.2.6 (1994).

¹⁴⁹ Americans with Disabilities Act and Architectural Barriers Act Accessibility Guidelines, § 308.3 (Jul. 23, 2004) (to be codified at 5 U.S.C. § 552(a) & 1 C.F.R. pt. 51); International Code Council § 308 (2003).

¹⁵⁰ A117.1 Task Group on Obstructed Reach Range and Extreme Physical Size, *Report of the September 28, 2001 Meeting of the Task Group on Obstructed Reach Range and Extremes of Physical Size* (2001).

¹⁵¹ D'Souza et al., *supra* note 132, at 4.

¹⁵² *Id.*

¹⁵³ International Code Council (2004).

¹⁵⁴ Canadian Human Rights Comm., *International Best Practices in Universal Design: A Global Review* (2006).

¹⁵⁵ ANSI § 4.2.1 (1961).

¹⁵⁶ ANSI 21 (1986).

¹⁵⁷ International Code Council § 403.3 (2004).

¹⁵⁸ 28 C.F.R. pt. 36 (2008) (§ 4.3.7 Slope).

¹⁵⁹ U.S. Access Bd., *Americans with Disabilities Act and Architectural Barriers Act Accessibility Guidelines* 154 (2004) (§ 403.3 Slope).

¹⁶⁰ *See* discussion *supra* Part II.C.

¹⁶¹ *See* Appendix 5 (Methodology Guide). The expert interviews and focus groups were conducted during the years 2008 and 2009 in multiple cities (hereinafter "Interviews").

¹⁶² The study's initial findings are available in *Current News from the United States Access Board, Access Currents*, Vol. 15 No.4 (July/August 2009), available at <http://www.access-board.gov/news/access%20currents/July-Aug09.htm#research>.

"[S]lopes that run perpendicular to the direction of travel, often referred to as the cross slope, have been identified as a key factor in usability according to several human factor studies involving people who use manual wheelchairs. ... [The investigation] ... by the Human Engineering Research Laboratory (HERL) at the University of Pittsburgh. ... reviewed existing research and surveyed people who use wheelchairs ..., including the interaction of slope, surface, and weather conditions on wheelchair travel. ... [R]esearchers developed a protocol for a follow-on human factors study ... [and] found that *while studies show that cross slopes make wheelchair travel more difficult, there was little consensus on methods or protocols for measuring these effects. Further, they determined that the measures used in most studies, such as energy consumption and perceived effort, cannot fully assess the complex effects of cross slope.* Few studies were found that investigated wheelchair propulsion in outdoor environments over a range of surfaces. Results ... confirmed that terrain features interact in complex ways and that the effects are more pronounced among certain populations. ... older adults, women, and people with progressive conditions, such as multiple sclerosis, or upper extremity impairment are most likely to experience difficulty negotiating cross slopes. This can be further aggravated by wheelchair design, such as configurations enhancing rearward stability. Based on the results ... the project team developed a protocol to measure the effects of cross slope using a cross sectional group of test subjects. Testing is currently underway on a range of cross slopes, running slopes, and surface conditions, including those that are smooth, irregular, and slippery. Devices developed by HERL to measure work, energy, distance-per-stroke, and pushrim forces are being used to capture data. Results of this research, including the preliminary study, will be posted on the Board's website once published." (emphasis added).

¹⁶³ The Public Rights-of-Way Access Advisory Committee was an officially chartered ad hoc committee, convened by the Access Board in 1999 for a specific purpose and disbanded in 2007 after the special report was completed.

¹⁶⁴ Public Rights of Way Advisory Comm., *Special Report: Accessible Public Rights of Way: Planning and Designing for Alterations 2* (2007).

¹⁶⁵ *Id.*

¹⁶⁶ Interviews, Industry representatives (Mar. 26, 2008) (see Methodology Guide, Appendix 5).

¹⁶⁷ Alison G. Vredenburgh & Kevin Williams, *Evaluating the Effects of Frost Heave on the Feasibility of Compliance with Existing Walkway Accessibility Standards*, 49th Annual Human Factors & Ergonomics Soc’y Proc. 813 (2005).

¹⁶⁸ Interviews, Industry representatives (Mar. 26, 2008).

¹⁶⁹ *Id.*

¹⁷⁰ David K. Ballast, *Handbook of Construction Tolerances* 75, 97-99, 239-241, & 327-329 (2007).

¹⁷¹ *Id.* at 12.

¹⁷² *Id.* at 8.

¹⁷³ *Id.* at 17.

¹⁷⁴ ICC/ANSI 117.1-2003, § 104.2 (2004).

¹⁷⁵ ANSI 117.1-1986 § 3.2.

¹⁷⁶ Office of Fair Housing & Equal Opportunity, U.S. Dep’t of Housing & Urban Dev., *Fair Housing Design Manual*, at 3.5, 5.7 (1998) [hereinafter “*Fair Housing Design Manual*”].

¹⁷⁷ Steinfeld, *Review of Literature*, *supra* note 25, at 104.

¹⁷⁸ International Code Council tbl. 405.2 (2004); U.S. Access Bd., *supra* note 159, at tbl. 405.2.

¹⁷⁹ ADAAG 2004 (identical to ICC/ANSI A117.1-2003) Fig. 406.3.

¹⁸⁰ Again, given importance, the U.S. Access Board has contracted a report to address tolerances and standards.

¹⁸¹ Vredenburgh et al., *supra* note 124, at 155 & 157 (citing Kockelman, *Sidewalk*, *supra* note 111).

¹⁸² *Id.*

¹⁸³ *Id.*

¹⁸⁴ From interviews with stakeholders.

¹⁸⁵ D’Souza, et al, *supra* note 132, at 1.

¹⁸⁶ *Id.* at 5-6.

¹⁸⁷ International Code Council § 308 (2004); ANSI (1986), at 22-23.

¹⁸⁸ Figures 3 and 4 are taken from ADA/ABA 2004, which is an identical version to ICC/ANSI A117.1-2003. See U.S. Access Bd., *supra* note 159, at fig. 308.3.2 (Figure 3) & fig. 308.3.1 (Figure 4). For Figure 5, see U.S. Dep’t of Justice, *supra* note 142, at fig. 6 (similar to ANSI 1986 A117.1, Fig 6).

¹⁸⁹ International Code Council, fig. 604.2 (2004); U.S. Access Bd., *supra* note 159, at 198 & figs. 308.2.1, 308.3.1.

¹⁹⁰ U.S. Dep’t of Justice, *supra* note 142, at Fig. 28.

¹⁹¹ U.S. Access Bd., *supra* note 159, at fig. 604.2.

¹⁹² Interviews (2009) (e.g., with ANSI, accessibility experts).

¹⁹³ D’Souza, et al., *supra* note 132, at 3.

¹⁹⁴ *Id.* at 5.

¹⁹⁵ *Id.* (reprinted with permission of authors). Note that Figure 8 is identical to Figure 1 *supra*, and reproduced here for convenience.

¹⁹⁶ *Fair Housing Design Manual*, *supra* note 176, at 7.3.

¹⁹⁷ *Id.* at 7.4.

¹⁹⁸ International Code Council § 308 (2004).

¹⁹⁹ *Fair Housing Design Manual*, *supra* note 176, at 7.47.

²⁰⁰ *Id.* at 7.48.

²⁰¹ The IDeA Center, founded in 1984, is an international leader of accessibility research and design.

²⁰² Edward Steinfeld, Jordana Maisel & Dave Feathers, *Standards and Anthropometry for Wheeled Mobility* 26 (Ctr. for Inclusive Design & Env'l Access, 2005).

²⁰³ U.S. Dep't of Justice, *supra* note 142.

²⁰⁴ U.S. Access Bd., *supra* note 159, at Fig 308.3.1.

²⁰⁵ D'Souza, et al., *supra* note 132, at 5 (reprinted with permission of authors).

²⁰⁶ ICC/ANSI A117.1-2003, Sec 309.1.

²⁰⁷ As Ballast notes, "Although many proposals have been made, there are no standard protocols for measuring the slope or cross-slope of a surface, especially one that is designed as part of an accessible route. . . . Some of the currently available methods of measuring slope are standardized and others are merely suggested." Ballast, *supra* note 170, at 327.

²⁰⁸ Our prior review of site slope accessibility did not address measurement error as a factor.

²⁰⁹ Ballast, *supra* note 170, at 327.

²¹⁰ *Id.*

²¹¹ *Id.* at 325-326.

²¹² International Code Council § 403 (2004).

²¹³ Ballast, *supra* note 170, at 327-329.

²¹⁴ Adapted, in part, from J.P. Salmen, U.S. Accessibility Codes and Standards: Challenges for Universal Design, in *Universal Design Handbook* at 12.1-12.8 (W. Preiser & E. Ostroff Eds. 2001).

²¹⁵ Design and Construction Requirements; Compliance with ANSI 117.1 Standards; Final Rule, 73 Fed. Reg. 63,610, 63,610-63,613 (Oct. 24, 2008) (to be codified at 24 C.F.R. pt 100).

²¹⁶ U.S. Access Bd., *supra* note 159.

²¹⁷ Fair Housing Accessibility Guidelines: Design Guidelines for Accessible/Adaptable Dwellings, 56 Fed. Reg. 9472 (Mar. 6, 1991).

²¹⁸ Am. Nat'l Standards Inst., ANSI Position Statement on Reference to Standards and Building Codes (Nov. 8, 2002).

²¹⁹ International Code Council (2004) *American National Standard, Accessible and Usable Buildings and Facilities, ICC/ANSI 117.1-2003*. Am. Nat'l Standards Inst., NY.

²²⁰ *Id.*

²²¹ Karl H. E. Kroemer, "Extra-Ordinary" Ergonomics: How to Accommodate Small and Big Persons, *The Disabled and Elderly, Expectant Mothers, and Children* 52, 53 & 99 (2006).

²²² David A. Winter, *Biomechanics and Motor Control of Human Movement* 1 (3d ed. 2005).

²²³ *Oxford American Dictionary*, 2009.

²²⁴ Consent Decree as to Defendants Camden Property Trust, Camden Subsidiary II, Inc., George F. Tibshernany Incorporated, and Becker Built. *United State of America. v. Camden Property*

Trust; Camden Subsidiary II, Inc.; George F. Tibshernany Incorporated, and Becker Built. VC-8-99-112-DWH (RJJ) (regarding Public and Common Use Area Retrofits.

²²⁵ Settlement Agreement and Consent Decree. Equal Rights Center v. Kettler & Kettler Management Corp., Case No. 1:07-cv-01017 (Aug. 13, 2009). *See* Appendix 6. Consent Decree. The Equal Rights Center v. Camden Property Trust & Camden Builders, Inc., Case No. PJM 07 CV 2357 (Filed 9/14/2009). *See* Appendix 6.

²²⁶ Interviews 2008, 2009.

²²⁷ *Id.*

²²⁸ *Id.*; Ballast, *supra* note 170, at 325.

²²⁹ Interviews 2008, 2009.

²³⁰ *Id.*

²³¹ *E.g.*, Stabila, Alltrade, Bon Tool Company, David White, Empire Level Co., Johnson Level & Tool, Klein Tools, Macklanburg Duncan, Marshalltown Co., Husky, LS Starrett, and Zircon.

²³² Jean Tessmer, Building Flatness into Walkways and Ramps, *Concrete Tech. Today*, 22(1) (Portland Cement Ass'n, Apr. 2001) at 2, available at <http://www.kmaccess.com/pdfs/PortlandCement.pdf>